



SPG8000A
Master Sync / Master Clock Reference Generator
Specifications and Performance Verification





SPG8000A
Master Sync / Master Clock Reference Generator
Specifications and Performance Verification

This document applies to firmware version 1.8 and above.

Copyright © Tektronix. All rights reserved. Licensed software products are owned by Tektronix or its subsidiaries or suppliers, and are protected by national copyright laws and international treaty provisions. Tektronix products are covered by U.S. and foreign patents, issued and pending. Information in this publication supersedes that in all previously published material. Specifications and price change privileges reserved.

TEKTRONIX and TEK are registered trademarks of Tektronix, Inc.

Contacting Tektronix

Tektronix, Inc.
14150 SW Karl Braun Drive
P.O. Box 500
Beaverton, OR 97077
USA

For product information, sales, service, and technical support:

- In North America, call 1-800-833-9200.
- Worldwide, visit www.tek.com to find contacts in your area.

Warranty

Tektronix warrants that this product will be free from defects in materials and workmanship for a period of one (1) year from the date of shipment. If any such product proves defective during this warranty period, Tektronix, at its option, either will repair the defective product without charge for parts and labor, or will provide a replacement in exchange for the defective product. Parts, modules and replacement products used by Tektronix for warranty work may be new or reconditioned to like new performance. All replaced parts, modules and products become the property of Tektronix.

In order to obtain service under this warranty, Customer must notify Tektronix of the defect before the expiration of the warranty period and make suitable arrangements for the performance of service. Customer shall be responsible for packaging and shipping the defective product to the service center designated by Tektronix, with shipping charges prepaid. Tektronix shall pay for the return of the product to Customer if the shipment is to a location within the country in which the Tektronix service center is located. Customer shall be responsible for paying all shipping charges, duties, taxes, and any other charges for products returned to any other locations.

This warranty shall not apply to any defect, failure or damage caused by improper use or improper or inadequate maintenance and care. Tektronix shall not be obligated to furnish service under this warranty a) to repair damage resulting from attempts by personnel other than Tektronix representatives to install, repair or service the product; b) to repair damage resulting from improper use or connection to incompatible equipment; c) to repair any damage or malfunction caused by the use of non-Tektronix supplies; or d) to service a product that has been modified or integrated with other products when the effect of such modification or integration increases the time or difficulty of servicing the product.

THIS WARRANTY IS GIVEN BY TEKTRONIX WITH RESPECT TO THE PRODUCT IN LIEU OF ANY OTHER WARRANTIES, EXPRESS OR IMPLIED. TEKTRONIX AND ITS VENDORS DISCLAIM ANY IMPLIED WARRANTIES OF MERCHANTABILITY OR FITNESS FOR A PARTICULAR PURPOSE. TEKTRONIX' RESPONSIBILITY TO REPAIR OR REPLACE DEFECTIVE PRODUCTS IS THE SOLE AND EXCLUSIVE REMEDY PROVIDED TO THE CUSTOMER FOR BREACH OF THIS WARRANTY. TEKTRONIX AND ITS VENDORS WILL NOT BE LIABLE FOR ANY INDIRECT, SPECIAL, INCIDENTAL, OR CONSEQUENTIAL DAMAGES IRRESPECTIVE OF WHETHER TEKTRONIX OR THE VENDOR HAS ADVANCE NOTICE OF THE POSSIBILITY OF SUCH DAMAGES.

[W2 – 15AUG04]

Table of Contents

| | |
|------------------------------------|------|
| Important safety information | v |
| General safety summary | v |
| Service safety summary | vii |
| Terms in the manual | viii |
| Terms on the product | viii |
| Symbols on the product | viii |
| Preface | ix |
| Product documentation | ix |

Base unit specifications

| | |
|--|---|
| Timebase characteristics | 1 |
| Interface characteristics | 2 |
| Power characteristics | 3 |
| Black and sine outputs | 4 |
| LTC outputs | 5 |
| Genlock VITC and LTC input | 6 |
| Word clock output specifications | 7 |
| Environmental characteristics | 8 |
| Mechanical characteristics | 9 |

Option BG specifications

| | |
|-----------------------------------|----|
| Black and composite outputs | 11 |
|-----------------------------------|----|

Option AG specifications

| | |
|--|----|
| AES-EBU serial digital audio outputs and silence outputs | 13 |
|--|----|

Option SDI specifications

| | |
|---|----|
| Option SDI serial video outputs | 15 |
| SDI7 video signal content | 17 |
| SDI embedded audio and ancillary data | 17 |

Option GPS specifications

| | |
|------------------------------------|----|
| GPS or GLONASS antenna input | 21 |
| GPS timebase | 22 |

Option PTP specifications

Option SX specifications

Option LX specifications

Performance verification

| | |
|---|----|
| Preparation | 31 |
| Instrument warm-up period | 31 |
| Save the Power On default settings | 31 |
| Set the SPG8000A to Factory Mode | 31 |
| Load the factory preset | 32 |
| Diagnostics tests | 32 |
| Required equipment | 32 |
| Test record | 33 |
| Diagnostics test procedure | 34 |
| SPG8000A base unit performance verification | 37 |
| Required equipment | 37 |
| Test record | 38 |
| Master clock accuracy test | 42 |
| Genlock function test | 43 |
| Genlock bit integrity and input gain test | 49 |
| LTC input gain and impedance test | 51 |
| Black output functional test and frame pulse test | 54 |
| Black output bit integrity test | 56 |
| Black amplitude and offset test (SD) | 57 |
| Trilevel sync output test (HD) | 58 |
| Black output rise and fall time test | 59 |
| Sine amplitude test | 60 |
| LTC level test | 61 |
| GPI output functional test | 62 |
| GPI input functional test | 64 |
| GPI input recall test | 65 |
| 48 kHz clock output level test | 66 |
| Option AG performance verification | 68 |
| Required equipment | 68 |

| | |
|---|-----|
| Test record | 69 |
| Procedures | 69 |
| AES-EBU serial digital audio output level test | 69 |
| Option BG performance verification | 73 |
| Required equipment | 73 |
| Test record | 74 |
| Procedures | 75 |
| Trilevel sync outputs test | 75 |
| Black output and offset test (SD) | 77 |
| Composite offset and gain test | 78 |
| Composite luminance - chrominance gain match test | 79 |
| Option GPS performance verification | 81 |
| Required equipment | 81 |
| Test record | 83 |
| Procedures | 84 |
| Set to factory mode and load factory preset | 84 |
| DC antenna output power voltage test | 84 |
| Antenna current and fault thresholds test | 85 |
| Lock to GPS or GLONASS signal from antenna test | 87 |
| Frequency and frame timing accuracy test | 89 |
| Internal frequency calibration test | 92 |
| Option PTP performance verification | 94 |
| Required equipment | 94 |
| Test record | 94 |
| Procedures | 95 |
| Master mode test | 95 |
| Slave mode tests | 99 |
| Options SDI and 3G performance verification | 104 |
| Required equipment | 104 |
| Test record | 105 |
| Preparation | 108 |
| Check for Option 3G | 108 |
| SDI diagnostics | 108 |
| Output functional and jitter test | 110 |
| Amplitude characterization | 111 |
| Set up the digital signal analyzer | 112 |
| Part B: characterization of the test system | 114 |
| SDI output amplitude | 115 |
| SDI rise and fall time | 117 |

Important safety information

This manual contains information and warnings that must be followed by the user for safe operation and to keep the product in a safe condition.

To safely perform service on this product, see the *Service safety summary* that follows the *General safety summary*.

General safety summary

Use the product only as specified. Review the following safety precautions to avoid injury and prevent damage to this product or any products connected to it. Carefully read all instructions. Retain these instructions for future reference.

Comply with local and national safety codes.

For correct and safe operation of the product, it is essential that you follow generally accepted safety procedures in addition to the safety precautions specified in this manual.

The product is designed to be used by trained personnel only.

Only qualified personnel who are aware of the hazards involved should remove the cover for repair, maintenance, or adjustment.

Before use, always check the product with a known source to be sure it is operating correctly.

This product is not intended for detection of hazardous voltages.

While using this product, you may need to access other parts of a larger system. Read the safety sections of the other component manuals for warnings and cautions related to operating the system.

When incorporating this equipment into a system, the safety of that system is the responsibility of the assembler of the system.

To avoid fire or personal injury

Use proper power cord. Use only the power cord specified for this product and certified for the country of use.

Ground the product. This product is grounded through the grounding conductor of the power cord. To avoid electric shock, the grounding conductor must be connected to earth ground. Before making connections to the input or output terminals of the product, ensure that the product is properly grounded. Do not disable the power cord grounding connection.

Power disconnect. The power cord disconnects the product from the power source. See instructions for the location. Do not position the equipment so that it is difficult to operate the power cord; it must remain accessible to the user at all times to allow for quick disconnection if needed.

Observe all terminal ratings. To avoid fire or shock hazard, observe all rating and markings on the product. Consult the product manual for further ratings information before making connections to the product.

Do not apply a potential to any terminal, including the common terminal, that exceeds the maximum rating of that terminal.

Do not operate without covers. Do not operate this product with covers or panels removed, or with the case open. Hazardous voltage exposure is possible.

Avoid exposed circuitry. Do not touch exposed connections and components when power is present.

Do not operate with suspected failures. If you suspect that there is damage to this product, have it inspected by qualified service personnel.

Disable the product if it is damaged. Do not use the product if it is damaged or operates incorrectly. If in doubt about safety of the product, turn it off and disconnect the power cord. Clearly mark the product to prevent its further operation.

Before use, inspect voltage probes, test leads, and accessories for mechanical damage and replace when damaged. Do not use probes or test leads if they are damaged, if there is exposed metal, or if a wear indicator shows.

Examine the exterior of the product before you use it. Look for cracks or missing pieces.

Use only specified replacement parts.

Do not operate in wet/damp conditions. Be aware that condensation may occur if a unit is moved from a cold to a warm environment.

Do not operate in an explosive atmosphere.

Keep product surfaces clean and dry. Remove the input signals before you clean the product.

Provide proper ventilation. Refer to the manual's installation instructions for details on installing the product so it has proper ventilation.

Slots and openings are provided for ventilation and should never be covered or otherwise obstructed. Do not push objects into any of the openings.

Provide a safe working environment. Always place the product in a location convenient for viewing the display and indicators.

Be sure your work area meets applicable ergonomic standards. Consult with an ergonomics professional to avoid stress injuries.

Use only the Tektronix rackmount hardware specified for this product.

Service safety summary

The *Service safety summary* section contains additional information required to safely perform service on the product. Only qualified personnel should perform service procedures. Read this *Service safety summary* and the *General safety summary* before performing any service procedures.

To avoid electric shock. Do not touch exposed connections.

Do not service alone. Do not perform internal service or adjustments of this product unless another person capable of rendering first aid and resuscitation is present.

Disconnect power. To avoid electric shock, switch off the product power and disconnect the power cord from the mains power before removing any covers or panels, or opening the case for servicing.

Use care when servicing with power on. Dangerous voltages or currents may exist in this product. Disconnect power, remove battery (if applicable), and disconnect test leads before removing protective panels, soldering, or replacing components.

Verify safety after repair. Always recheck ground continuity and mains dielectric strength after performing a repair.

Terms in the manual

These terms may appear in this manual:



WARNING. *Warning statements identify conditions or practices that could result in injury or loss of life.*



CAUTION. *Caution statements identify conditions or practices that could result in damage to this product or other property.*

Terms on the product

These terms may appear on the product:

- DANGER indicates an injury hazard immediately accessible as you read the marking.
- WARNING indicates an injury hazard not immediately accessible as you read the marking.
- CAUTION indicates a hazard to property including the product.

Symbols on the product



When this symbol is marked on the product, be sure to consult the manual to find out the nature of the potential hazards and any actions which have to be taken to avoid them. (This symbol may also be used to refer the user to ratings in the manual.)

The following symbols may appear on the product:



CAUTION
Refer to Manual



Protective Ground
(Earth) Terminal

Preface

This manual describes the specifications and performance verification procedures for the SPG8000 Master Sync / Clock Reference Generator, with or without all of the available options.

This manual is divided into two sections:

- Specifications provides physical and electrical characteristics.
- Performance verification provides procedures to verify the warranted characteristics of the base unit and all options.

Product documentation

The following table contains a list of documents that include user information about the SPG8000A generator.

Table 1: Product documentation

| Document | Tektronix Part Number | Description | Availability | |
|--|--|---|--------------|-------------|
| | | | Print | Web |
| Installation and Safety Instructions | 071-3479-xx (English) 077-1214-xx (Japanese) 077-1215-xx (Russian) | Describes how to install the instrument and provides basic operating information | ✓ | ✓ ✓ ✓ |
| User Manual | 077-1216-xx 077-1217-xx (Japanese) 077-1218-xx (Russian) | Provides detailed operating information | | ✓ |
| Specifications and Performance Verification | 077-1219-xx | Lists the product specifications and provides procedures for verifying the performance of the instrument | | ✓ |
| Service Manual | 077-1220-xx | Describes how to service the instrument to the module level (such as circuit boards and fuses) | | ✓ |
| Declassification and Security Instructions | 077-1221-xx | Describes how to clear or sanitize the data storage (memory) devices in the product for customers with data security concerns. | | ✓ |
| Release Notes | 077-1222-xx | Describes the new features, improvements, and limitations of the instrument firmware | | ✓ |
| Video Sync Pulse Generator and Electronic Changeover Unit System Integration Technical Reference | 077-0563-xx (ECO422D) 077-0877-xx (ECO8000, ECO8020) | Provides information for system integrators who are designing systems for high-definition (HD) and standard-definition (SD) digital video content where Tektronix electronic changeover units and video sync pulse generators are to be deployed. | | ✓ |

Base unit specifications

The information in this section provides electrical, mechanical, and environmental specifications for the SPG8000A generator base unit.

The performance requirements listed in the electrical characteristics portion of these specifications apply over an ambient temperature range of 0 °C to +50 °C. The rated accuracies are valid when the instrument is calibrated at an ambient temperature range of +20 °C to +30 °C, after a warm-up time of 20 minutes.

The following tables list certification and compliance information, and the electrical, environmental, and mechanical characteristics of the SPG8000A generator base unit. Specifications for optional features are provided later in this manual.

Timebase characteristics

| | |
|---|--|
| Frequency accuracy in internal mode | $\pm 135 \times 10^{-9}$ over 1 year calibration interval After 20 minute instrument warm up. Includes drift and temperature variation. Initial setting after adjustment will typically be within 10×10^{-9} . |
| Frequency accuracy over temperature | $\pm 2 \times 10^{-9}$ for ± 5 °C variation, $\pm 10 \times 10^{-9}$ for 0 to 50 °C |
| Frequency drift aging | $< \pm 100 \times 10^{-9}$ per year for internal, stay current frequency and stay genlock modes at constant temperature |
| Frequency variation from vibration and shock | $\pm 25 \times 10^{-9}$ typical from 6 ms half-sine shocks over 20 g |
| Genlock range | $\pm 7.5 \times 10^{-6}$ |

Interface characteristics

| | |
|-------------------------------|--|
| Keyboard | 17 buttons with green LED backlight, 6 Fault indicators with Red / Green backlight. |
| Display | LCD with 2 line x 40 characters with backlight, 153 x 15 mm active area. |
| Ethernet functionality | 1000base-T, 100BASE-TX and 10BASE-T Compliant with IEEE 802.3-2000 and ANSI X3.263-1995 standards |
| Ethernet connector | <p>8P8C connector supporting 10/100 BaseT</p> <p>The 8P8C (also known as RJ45) connector has built in LEDs. The Green LED indicates an active connection. The Yellow LED indicates speed. ON = 100, OFF = 10.</p> <p>Wiring follows TIA/EIA-568-B T568A standard Ethernet pin assignments.</p> |
| GPI | <p>General Purpose Interface for uses such as setting presets or driving alarms. The 15 pin connection has 1 configurable input and 2 configurable outputs. The 9 pin carries the same signal as the 15 pin plus three inputs used to select presets and one more configurable output.</p> <p>Logical functions The function of some of the input and outputs may be set from the user interface.</p> <p>Ground closure input signaling TTL thresholds of 0.8 V low and 2.0 V high, 5 V max input, -0.5 V min input. Pull low to assert. Has internal 10 kΩ pull-up to +5 V on each input.</p> <p>Ground closure input timing Inputs must be asserted and stable for at least 60 ms to be recognized reliably. Inputs that are stable for 40 ms or less will not be recognized.</p> <p>Ground closure output characteristics Three open collector outputs Has internal 10 kΩ pull-up to +5 V. Max current allowed is 100 mA. On resistance is approximately 4 Ohms</p> <p>Maximum output current 250 mA On resistance is approximately 4 Ohms</p> <p>Output duration Signal alarms asserted as long as the error condition exists. Timer based outputs asserted for the 1 second that the selected time counter matches the user defined time.</p> |
| USB | |
| Type | Host |
| Speed | USB 1.0 and 2.0 full-speed (12 Mb/s) |

Power characteristics

AC power source

Rating voltage 100 V to 240 V



WARNING. To reduce the risk of fire and shock, ensure the mains supply voltage fluctuations do not exceed 10% of the operating voltage range.

Frequency 50/60 Hz

Maximum power 130 VA

Actual power varies with type and number of modules installed. Base instrument without modules typically draws 20 watts.

Surge current, typical 20 A peak (25 °C) for ≤ 5 line cycles, after the instrument has been turned off for at least 30 seconds.

Inrush current, typical 10 A RMS half cycle at initial turn on as per EN55103-1:2009 Annex B.

Supply connection Detachable IEC cord set, locking versions available for some geographies.
Locking cords for: USA, Japan, UK, Europe, Switzerland, China, and Australia.

Dual supply hot swap The instrument can run with either or both supplies. Any plugging or un-plugging supplies or AC input to the supplies will not cause disruption in the system, as long as at least one supply is active. The supplies take 1-2 sec to power up after AC is applied.

Dual supply operation When two supplies are present, one will be used to power the instrument and the other will be in an unloaded backup mode.
Keeping the backup supply unloaded minimizes its aging and maximizes the life available if the primary supply fails.

Power supply life tracking Each supply maintains a usage history, which provides the ability to recommend replacement. Each supply tracks the time in use, the time in standby, and the Temperature Weighted Hours calculation that helps predict the end of life on the supply. The Temperature Weighted Hour calculation uses the temperature at each hour to predict the failure point on the supply.

Power supply life expectancy, typical 15 years (131,400 hours) at 25 °C outside air, 5 years at 50 °C outside air temperature.
The Temperature Weighed Hours calculation accounts for the aging acceleration at higher temperatures and normalizes it to hours at 25 °C.

Power supply load testing The backup supply will periodically be tested to insure it can support the instrument load should the primary supply fail. This load is approximately 55 watts and is applied for about 6 sec.

Black and sine outputs

| | |
|---|---|
| Number of outputs | Three outputs, all can be black, or Black #3 can be configured as 10 MHz sine wave. Black #2 can be configured to blank during certain errors to trigger an ECO change-over. |
| Formats | Each output is individually selectable between Bi-level NTSC with or without field ref, NTSC No setup with or without field pulse, PAL with or without field ref, or Tri-level. The base outputs can only generate tri-level at one clock rate, so all three can be any one of the two sets: Set 1: 1080i59.94, 720p59.94, 1080p23.98, 1080sf23.98. Set 2: 1080p29.97 1080i60, 1080i50, 720p60, 720p50, 1080p24, 1080p30, 1080sf24, 1080p25. The three outputs can also generate 1 pps outputs. |
| Standards supported | RS170A, SMPTE RP154, SMPTE318M, EBU N14, SMPTE240M, 274M, 296M, and RP211. |
| Output impedance | 75 Ohms |
| Return loss, typical | 40 dB from 300 kHz to 5 MHz, 25 dB to 30 MHz |
| Amplitude in DC output mode | ±1% on difference of 0 and 700 mV DC levels |
| Amplitude | Standard level for selected format ±2% |
| Offset | 0 ±50 mV |
| Offset in DC output mode | 0 ±40 mV |
| Bi-Level sync rise and fall time, typical | 140 ns for NTSC, 250 ns for PAL |
| Tri-Level sync rise and fall time, typical | 50 ns |
| SCH | ±5 deg for NTSC and PAL |
| Timing adjust composite | Each output individually adjustable over ± ½ the color frame with 0.5 deg of subcarrier resolution. |
| Timing adjust HD rates | Each output individually adjustable over ±½ the frame with <20 ns resolution. |
| Signal-to-Noise ratio, typical | >60 dB RMS noise relative to 700 mV. DC to 20 MHz. |
| Sine output amplitude | 1.5 V _{p-p} ±10% |
| 1 pulse per second (pps), typical | |
| Amplitude | 1 V into 75 ohms. |
| Duration | 10 ms |
| Timing | Rising edge aligned within 100 ns of start of second reference source. GPS antenna cable length compensation must be applied. |

LTC outputs

| | |
|--|--|
| Formats | 23.98, 24, 25, 30, 30 drop as per SMPTE 12M |
| Output level accuracy | 5 V \pm 10% at max level. Differential into 600 Ω |
| Output level range | Adjustable from 0.5 to 5 V into 600 Ω |
| Output level adjust resolution, typical | 0.5 V steps |
| Output rise and fall time, typical | 40 μ s |
| Output impedance | 30 Ω for each output |
| Output load | 600 nominal, 150 min |
| Timing adjust range | \pm 1 half a frame for selected format |
| Timing adjust resolution | 10 μ s steps |
| Timecode offset range | 24 hours |
| Timecode offset resolution | 1 frame |

Genlock VITC and LTC input

Genlock

| | |
|--|---|
| Input type | Two 75 Ω BNC connectors; passive loop through |
| Input formats | Bi-Level NTSC, NTSC with SMPTE318 10 field flag, PAL; Tri-level HD 1080i59.94, 1080i50, 720p59.94, 720p60, 1080p23.98, 1080p24, 1080p29.97, 1080p30, 1080p25; CW 10 MHz |
| Input video signal level range, typical | -8 to +6 dB with nominal operation |
| Input CW signal level range, typical | 0.5 to 2 V_{p-p} signal |
| Input DC tolerance | +5 V max or damage may occur |
| Hum tolerance | -3 dB of 50 or 60 Hz hum |
| White noise tolerance | -33 dB Min SNR of 5 MHz BW noise |
| SCH tolerance | +40 deg |
| Return loss, typical | \geq 30 dB from 300 kHz to 10 MHz |

Jitter in NTSC and PAL burst lock, typical <0.5° with \pm 3 dB amplitude change and >40 dB S/N ratio

Jitter in tri-level sync lock, typical <1 ns with \pm 3 dB amplitude change and >40 dB S/N ratio

Jitter in CW lock, typical <1 ns with 1 V_{p-p} \pm 3 dB amplitude change and >40 dB S/N ratio

LTC

| | |
|-------------------------------------|---|
| Input | LTC1 output can be configured as an input |
| Input – formats supported | 23.98, 24, 25, 29.97 drop frame, and 30 Hz |
| Input – timing to video | To correctly associate the LTC with a given video frame, the LTC start bit should be from 32 μ s before to 160 μ s after the start of the first broad pulse in vertical blanking of a compatible frame rate being used as the genlock input. This is as specified in SMPTE12M Will accept input timing anywhere in the frame, however near the middle of the video frame the timing may be interpreted as related to the previous or next video frame. A status screen indicates the detected timing in ms |
| Input – signal voltage range | 0.5 to 10 V_{p-p} differential, 1 V to 5 V_{p-p} single ended |
| Input – noise tolerance | -30 dB SNR RMS white noise with 10 kHz BW to the p-p signal level, or -10 dB SNR for 5 MHz white noise |
| Input – hum tolerance | 0 dB hum to signal ratio |
| Input – error immunity | 100 consecutive frames with consistent time code must be detected for time to be considered valid |
| Input impedance, typical | Nominal 600 Ω differential, 300 Ω single-ended |

VITC

| | |
|--|---|
| Video formats supported | +VITS can be decoded from NTSC and PAL as per SMPTE 12M-1 2008 |
| Lines on which VITC is detected | +VITC is detected on lines 6 to 22 for all formats (ERI) 12M specified range for NTSC is lines 10 to 20 |

| | |
|--------------------------|---|
| Timing in line | VITC conforming to the standard timing will be detected. VITC slightly outside the normal timing range may also be detected, but it must not run into burst or sync |
| Allowed video SNR | VITC will be correctly decoded for signals with more than 30 dB SNR |

Word clock output specifications

| | |
|---|---|
| Connector | BNC |
| Output | 48 kHz clock |
| Output level range and coupling | Selectable as 1 V AC coupled or 2.5 V DC coupled into 75 Ω . Unterminated, this gives 2 V or a 5 V swing |
| Output rise and fall time, typical | 33 ns |
| Output impedance | 75 Ω |
| Association to video | May be configured to be phased up with any of the three internal frame pulses |
| Alignment to video, typical | At default timing, a positive going Word Clock transition will align to the appropriate event in the selected video signal within $\pm 1.0 \mu\text{s}$ |

Environmental characteristics

Temperature

| | |
|---------------------|---|
| Operating | 0 °C to +50 °C, with 15 °C/hour maximum gradient, noncondensing, derated 1 °C per 300 m above 1,500 m altitude. |
| Nonoperating | -20 °C to +60 °C, with 15 °C/hour maximum gradient, without disk media installed in disk drives. |

Relative humidity

| | |
|---------------------|---|
| Operating | 20% to 80% at up to +30 °C, maximum wet-bulb temperature of +29 °C (derates relative humidity to 20% relative humidity at +50 °C) |
| Nonoperating | 5% to 90% (relative humidity) at up to +40 °C, maximum wet-bulb temperature of 40.0 °C (derates relative humidity to 30% relative humidity at +60 °C) |

Altitude

| | |
|---------------------|--|
| Operating | To 3.0 km (10,000 feet) Maximum operating temperature decreases 1 °C each 300 m above 1.5 km. |
| Nonoperating | To 15 km (50,000 feet) |

Vibration

| | |
|---------------------|--|
| Operating | 0.27 GRMS, 5 Hz to 500 Hz, 10 min per axis, three axes |
| Nonoperating | 2.28 GRMS, 5 Hz to 500 Hz, 10 min per axis, three axes |

Shock operating

Half-sine mechanical shocks, 30 g peak amplitude, 11 ms duration, 3 drops in each direction of each axis (18 total)

Clearance

| | |
|-------------|------|
| Side | 5 cm |
| Rear | 5 cm |

Mechanical characteristics

Dimensions

| | |
|---------------|------------------|
| Height | 44 mm (1.7 in) |
| Width | 483 mm (19 in) |
| Depth | 567 mm (22.3 in) |

| | |
|---------------------------------|--|
| Weight ¹, net | Approximately 6 kg (base unit only, without rack rail) |
|---------------------------------|--|

| | |
|------------------------|--|
| Shipping weight | Typical packaged weight of product: 10.635 kg. |
|------------------------|--|

| | |
|---------------------------|----------------------------------|
| Package dimensions | 23 in. W x 30 in. L x 10.5 in. H |
|---------------------------|----------------------------------|

¹ Weight of the SPG8000 base unit varies depending on the number and type of modules installed.

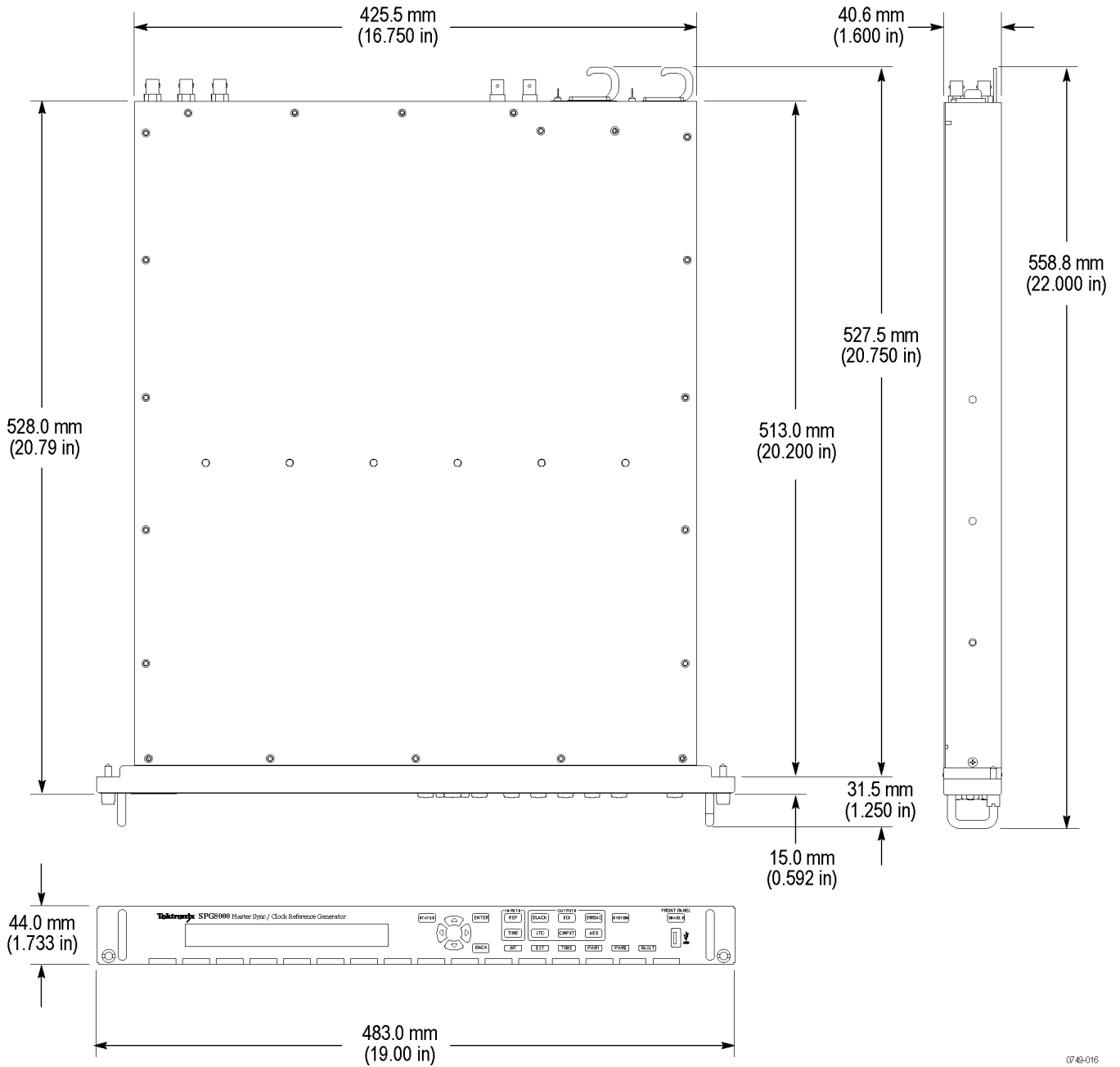

0749-016

Figure 1: SPG8000 dimensions

Option BG specifications

The following tables list the electrical characteristics and the environmental characteristics of the BG Option.

Black and composite outputs

| | |
|---|--|
| Connector | BNC |
| Number of black outputs | 2 BLACK4 and BLACK5 |
| Formats on black outputs | Each output is individually selectable between Bi-level NTSC with or without field ref, NTSC No setup with or without field pulse, PAL with or without field ref, or Tri-level. The BG option outputs can only generate tri-level at one clock rate, so both can be any one of the two sets: Set 1: 1080i59.94, 720p59.94, 1080p23.98, 1080sf23.98, 1080p29.97. Set 2: 1080i60, 1080i50, 720p60, 720p50, 1080p24, 1080p30, 1080sf24, 1080p25 |
| Number of composite outputs | 2 CPST 1 and CPST 2 |
| Composite formats | NTSC, NTSC No setup, PAL |
| Output impedance | 75 Ω |
| Return loss, typical | ≥ 30 dB To 30 MHz |
| Sync amplitude accuracy | |
| NTSC | 287 mV \pm 2% |
| PAL | 300 mV \pm 2% |
| Tri-Level | 300 mV \pm 2% |
| Composite outputs luminance amplitude | |
| NTSC | 714 mV \pm 1% |
| PAL | 700 mV \pm 1% |
| Tri-Level | 700 mV \pm 1% |
| Sync and composite amplitude in DC output mode | $\pm 1\%$ on the difference between the 0 and 700 mV DC levels |
| Chroma luma gain match | 2% on Composite test outputs |
| Blanking level | $< \pm 50$ mV |

Blanking level in DC output mode ± 10 mV

Bi-Level sync rise and fall time for black and composite outputs, typical

| | |
|------|--------|
| NTSC | 140 ns |
| PAL | 250 ns |

Tri-Level sync rise and fall time for black outputs, typical 50 ns

SCH phase accuracy $0^\circ \pm 5^\circ$

Timing offset

| | |
|------------|----------------------|
| Range | One full color frame |
| Resolution | |
| Bi-Level | ≈ 18.5 ns |
| Tri-Level | ≈ 13.5 ns |

Option AG specifications

The following tables list the electrical and environmental characteristics of the AG Option.

AES-EBU serial digital audio outputs and silence outputs

| | |
|--------------------------------------|--|
| Connector | 4 for Unbalanced AES, BNC 1 for DARS, BNC |
| Number of channels | 8 for AES 2 for DARS |
| Audio tone | |
| Frequency | The AES channels may be independently set to any of these 30 discrete settings: 50, 100, 150, 200, 250, 300, 400, 500, 600, 750, 800, 1 k, 1.2 k, 1.5 k, 1.6 k, 2 k, 2.4 k, 3 k, 3.2 k, 4 k, 4.8 k, 5 k, 6 k, 8 k, 9.6 k, 10 k, 12 k, 15 k, 16 k, 20 kHz |
| Level | 0 to -60 dBFS in 1 dB steps |
| Pre-emphasis | None |
| Output level | 1 V \pm 0.1 V into 75 Ω Measured across 75 Ω . |
| Output offset | < 50 mV into 75 Ω |
| Required receiver termination | 75 Ω \pm 10% |
| Jitter | <20 ns |
| Rise and fall times | 37 ps \pm 7 ps, 10 to 90% Measured from the 10% to 90% points |
| Timing range | \pm 160 ms relative to the selected video frame |
| Timing resolution | 1 μ s |

Option SDI specifications

The following tables list the electrical, mechanical, and environmental characteristics of the SDI Dual Channel SD/HD/3G SDI Video Generator option.

Option SDI serial video outputs

| | |
|--|--|
| Video channels | 2 The two channels may be independently set for bit rate, format, color space, and others. |
| Video outputs | 4, 2 per channel |
| Format | Supports SD, HD, and 3Gb signals. Compatible with SMPTE 125, SMPTE 259, SMPTE 274, SMPTE 292, SMPTE 296, SMPTE 424M, SMPTE 425M, and ITU-R BT601. The following tables list the supported formats and sample structures: (See Table 2: SDI7 SD-525 (720 x 486) on page 18.) (See Table 3: SDI7 SD-625 (720 x 576) on page 18.) (See Table 4: SDI7 HD-SDI (1920 x 1080) on page 18.) (See Table 5: SDI7 HD-SDI (1280 x 720) on page 18.) (See Table 6: SDI7 3G level A (1920 x 1080) (option 3G only) on page 18.) (See Table 7: SDI7 3G level A (1280 x 720) (option 3G only) on page 19.) (See Table 8: SDI7 3G level A (2K x 1080) (option 3G only) on page 19.) (See Table 9: SDI7 3G level B (1920 x 1080) (option 3G only) on page 19.) (See Table 10: SDI7 3G level B (2K x 1080) (option 3G only) on page 19.) (See Table 11: SDI7 3G level B (2xHD 1920 x 1080) (option 3G only) on page 19.) (See Table 12: SDI7 3G level B (2xHD 1280 x 720) (option 3G only) on page 19.) |
| Output | |
| Type | 75 Ω BNC |
| Level | 800 mV _{p-p} \pm 3% on level after ringing has settled 18 to 28 °C range Measure on 20 Bit square wave in calibration mode |
| Level variation with temperature, typical | \pm 1% typical for 0 to 50 °C. |

Rise and fall times

| | |
|-------------------|---|
| HD and 3Gb | 135 ps max. (20% to 80%) measured between runs of at least 3 bits times of constant level. 70 ps typical |
| SD | 400 ps min and 1000 ps max (20% to 80%) measured between runs of at least 3 bits times of constant level. 700 ps typical |

3Gb

| | |
|----------------------------------|--------------------|
| Alignment jitter, typical | 40 ps p-p, 0.12 UI |
| Timing jitter, typical | 80 ps p-p, 0.24 UI |

HD

| | |
|----------------------------------|--------------------|
| Alignment jitter, typical | 40 ps p-p, 0.06 UI |
| Timing jitter, typical | 80 ps p-p, 0.12 UI |

SD

| | |
|----------------------------------|----------------------|
| Alignment jitter, typical | 200 ps p-p, 0.054 UI |
| Timing jitter, typical | 200 ps p-p, 0.054 UI |

| | |
|-----------------------------|--|
| Return loss, typical | ≥20 dB, 5 MHz to 2.0 GHz ≥12 dB, 2.0 GHz to 3 GHz |
|-----------------------------|--|

| | |
|---------------------------|-----|
| Overshoot, typical | ≤1% |
|---------------------------|-----|

| | |
|---|---|
| DC shift during HD and 3Gb mode 32 microsecond pathological pattern, typical | ≤ 25 mV Amount of shift depends on video format. Many 3Gb formats will be less than ½ of this. |
|---|---|

Signal timing

| | |
|--|---|
| 3Gb, HD, and SD when in Zero H based digital timing mode, typical | Signals are nominally timed, so that the timing reference point on the serial output is aligned within 0.5 μs of the reference edge of an analog reference signal at the same frame rate. Vertically, the first lines with the broad pulses are aligned. Timing adjust of lines is in terms of the raster image, so for Level B signals, this corresponds to ½ of the time for the multiplexed combination of two lines. |
| HD and SD when in Legacy D to A Analog timing mode, typical | Signals are nominally timed, so that after the SDI signal is passed through a D to A conversion, the sync of the resulting analog signal is aligned within 0.5 μs of the reference edge of an analog reference signal at the same frame rate. Vertically, the first lines with the broad pulses are aligned. |

SDI7 video signal content

Accuracy of synthesizer generated test signals, typical 0.2%

Signal rise and fall time, typical

| | |
|--|---|
| 3Gb 1080p 50, 59.95 and 60 signals with 148.5 MHz Luma pixel rate | Y, R, G, B = 16.6 ns Cb/Cr = 33.3 ns except for RP219 which has Y, R, G, B, Cb, Cr = 27.5 ns |
| 3Gb and HD signal with 74.25 MHz and 74.176 MHz luma pixel rate | Y, R, G, B = 33.3 ns Cb/Cr = 66.6 ns except for RP219 which has Y, R, G, B, Cb, Cr = 55 ns |
| SD | Y = 200 ns Cb/Cr = 400 ns except for RP219 which has Y, Cb, Cr = 300 ns |

2T pulse HAD

For 148 MHz Luma pixel rate signals, HAD = 16.66 ns.
For 74 MHz Luma pixels rate signals, HAD = 33.33 ns.
For SD signals at 13.5 MHz Luma pixel rate, HAD is 200 ns (2T5).

SDI embedded audio and ancillary data

| | |
|---------------------------------|--|
| Generator embedded audio | Embedded Audio may be inserted in the ancillary data space of the SD, HD, and 3Gb video outputs. |
| Number of audio channels | SD, HD and Level A 3Gb: 16 channels in 4 groups in each link; 8 AES/EBU audio pairs. Level B 3Gb: 32 channels in 4 groups in each link; 16 AES/EBU audio pairs. |
| Audio | |
| Tones | 10 Hz to 20 kHz in half Hz steps. |
| Levels | -60 to 0 dBFS in 1 dB steps. |
| Timecode | ATC-LTC and ATC-VITC can be inserted in the signal as a user-defined time or, if Option GPS is present, the timecode can be the time of day of the GPS or GLONASS signal. |
| Arbitrary ANC insertion | Arbitrary Type 2 ANC data packet with user selectable DID (8 bits, 01h-7Fh), SDID (8 bits, 01h-FFh), Data Count (DC) (numeric, 0-255 words), User Data Words (UDW) (hex, 0-3FF per word). Number of editable words in string indicated by DC value. User specifiable location (for example, HANC/VANC, line number) for this packet. |
| Generator ancillary data | SMPTE 352 Embedded Ancillary Data is placed on the video outputs as per SMPTE 425M. |

Table 2: SDI7 SD-525 (720 x 486)

| Structure | | | 59.94i | 50i | 60i | 23.98p | 24p | 25p | 29.97p | 30p | 50p | 59.94p | 60p | 23.98psf | 24psf | 25psf | 29.97psf | 30psf | |
|-----------|-------|-----|--------|-----|-----|--------|-----|-----|--------|-----|-----|--------|-----|----------|-------|-------|----------|-------|--|
| YCbCr | 4:2:2 | 10b | X | | | | | | | | | | | | | | | | |

Table 3: SDI7 SD-625 (720 x 576)

| Structure | | | 59.94i | 50i | 60i | 23.98p | 24p | 25p | 29.97p | 30p | 50p | 59.94p | 60p | 23.98psf | 24psf | 25psf | 29.97psf | 30psf | |
|-----------|-------|-----|--------|-----|-----|--------|-----|-----|--------|-----|-----|--------|-----|----------|-------|-------|----------|-------|--|
| YCbCr | 4:2:2 | 10b | | X | | | | | | | | | | | | | | | |

Table 4: SDI7 HD-SDI (1920 x 1080)

| Structure | | | 59.94i | 50i | 60i | 23.98p | 24p | 25p | 29.97p | 30p | 50p | 59.94p | 60p | 23.98psf | 24psf | 25psf | 29.97psf | 30psf |
|-----------|-------|-----|--------|-----|-----|--------|-----|-----|--------|-----|-----|--------|-----|----------|-------|-------|----------|-------|
| YCbCr | 4:2:2 | 10b | X | X | X | X | X | X | X | X | | | | X | X | X | X | X |

Table 5: SDI7 HD-SDI (1280 x 720)

| Structure | | | 59.94i | 50i | 60i | 23.98p | 24p | 25p | 29.97p | 30p | 50p | 59.94p | 60p | 23.98psf | 24psf | 25psf | 29.97psf | 30psf |
|-----------|-------|-----|--------|-----|-----|--------|-----|-----|--------|-----|-----|--------|-----|----------|-------|-------|----------|-------|
| YCbCr | 4:2:2 | 10b | | | | X | X | X | X | X | X | X | X | | | | | |

Table 6: SDI7 3G level A (1920 x 1080) (option 3G only)

| Structure | | | 59.94i | 50i | 60i | 23.98p | 24p | 25p | 29.97p | 30p | 50p | 59.94p | 60p | 23.98psf | 24psf | 25psf | 29.97psf | 30psf |
|-----------|-------|-----|--------|-----|-----|--------|-----|-----|--------|-----|-----|--------|-----|----------|-------|-------|----------|-------|
| YCbCr | 4:4:4 | 12b | X | X | X | X | X | X | X | X | | | | X | X | X | X | X |
| | | 10b | X | X | X | X | X | X | X | X | | | | X | X | X | X | X |
| YCbCr+A | 4:2:2 | 10b | X | X | X | X | X | X | X | X | | | | X | X | X | X | X |
| YCbCr | | 12b | X | X | X | X | X | X | X | X | | | | X | X | X | X | X |
| GBR | 4:4:4 | 12b | X | X | X | X | X | X | X | X | | | | | | | | |
| | | 10b | X | X | X | X | X | X | X | X | | | | X | X | X | X | X |
| GBR+A | 4:2:2 | 10b | X | X | X | X | X | X | X | X | | | | X | X | X | X | X |
| | | 12b | X | X | X | X | X | X | X | X | | | | X | X | X | X | X |

Table 7: SDI7 3G level A (1280 x 720) (option 3G only)

| Structure | | | 59.94i | 50i | 60i | 23.98p | 24p | 25p | 29.97p | 30p | 50p | 59.94p | 60p | 23.98psf | 24psf | 25psf | 29.97psf | 30psf |
|-----------|-------|-----|--------|-----|-----|--------|-----|-----|--------|-----|-----|--------|-----|----------|-------|-------|----------|-------|
| YCbCr | 4:4:4 | 10b | | | | X | X | X | X | X | X | X | X | | | | | |
| YCbCr+A | 4:4:4 | 10b | | | | X | X | X | X | X | X | X | X | | | | | |
| GBR | 4:4:4 | 10b | | | | X | X | X | X | X | X | X | X | | | | | |
| GBR+A | 4:4:4 | 10b | | | | X | X | X | X | X | X | X | X | | | | | |

Table 8: SDI7 3G level A (2K x 1080) (option 3G only)

| Structure | | | 59.94i | 50i | 60i | 23.98p | 24p | 25p | 29.97p | 30p | 50p | 59.94p | 60p | 23.98psf | 24psf | 25psf | 29.97psf | 30psf |
|-----------|-------|-----|--------|-----|-----|--------|-----|-----|--------|-----|-----|--------|-----|----------|-------|-------|----------|-------|
| XYZ | 4:4:4 | 12b | | | | X | X | X | X | X | | | | X | X | X | X | X |
| GBR | | | | | | X | X | X | X | X | | | | | | | | |

Table 9: SDI7 3G level B (1920 x 1080) (option 3G only)

| Structure | | | 59.94i | 50i | 60i | 23.98p | 24p | 25p | 29.97p | 30p | 50p | 59.94p | 60p | 23.98psf | 24psf | 25psf | 29.97psf | 30psf |
|-----------|-------|-----|--------|-----|-----|--------|-----|-----|--------|-----|-----|--------|-----|----------|-------|-------|----------|-------|
| YCbCr | 4:4:4 | 12b | X | X | X | X | X | X | X | X | | | | X | X | X | X | X |
| | | 10b | X | X | X | X | X | X | X | X | | | | X | X | X | X | X |
| YCbCr+A | | 10b | X | X | X | X | X | X | X | | | | | X | X | X | X | X |
| YCbCr | 4:2:2 | 12b | X | X | X | X | X | X | X | X | | | | X | X | X | X | X |
| | | 10b | | | | | | | | | X | X | X | | | | | |
| YCbCr+A | | 12b | X | X | X | X | X | X | X | | | | | X | X | X | X | X |
| GBR | 4:4:4 | 12b | X | X | X | X | X | X | X | X | | | | X | X | X | X | X |
| | | 10b | X | X | X | X | X | X | X | X | | | | X | X | X | X | X |
| GBR+A | | 10b | X | X | X | X | X | X | X | | | | | X | X | X | X | X |

Table 10: SDI7 3G level B (2K x 1080) (option 3G only)

| Structure | | | 59.94i | 50i | 60i | 23.98p | 24p | 25p | 29.97p | 30p | 50p | 59.94p | 60p | 23.98psf | 24psf | 25psf | 29.97psf | 30psf |
|-----------|-------|-----|--------|-----|-----|--------|-----|-----|--------|-----|-----|--------|-----|----------|-------|-------|----------|-------|
| XYZ | 4:4:4 | 12b | | | | X | X | X | X | X | | | | X | X | X | X | X |
| GBR | | | | | | X | X | X | X | X | | | | X | X | X | X | X |

Table 11: SDI7 3G level B (2xHD 1920 x 1080) (option 3G only)

| Structure | | | 59.94i | 50i | 60i | 23.98p | 24p | 25p | 29.97p | 30p | 50p | 59.94p | 60p | 23.98psf | 24psf | 25psf | 29.97psf | 30psf |
|-----------|-------|-----|--------|-----|-----|--------|-----|-----|--------|-----|-----|--------|-----|----------|-------|-------|----------|-------|
| YCbCr | 4:2:2 | 10b | X | X | X | X | X | X | X | X | | | | X | X | X | X | X |

Table 12: SDI7 3G level B (2xHD 1280 x 720) (option 3G only)

| Structure | | | 59.94i | 50i | 60i | 23.98p | 24p | 25p | 29.97p | 30p | 50p | 59.94p | 60p | 23.98psf | 24psf | 25psf | 29.97psf | 30psf |
|-----------|-------|-----|--------|-----|-----|--------|-----|-----|--------|-----|-----|--------|-----|----------|-------|-------|----------|-------|
| YCbCr | 4:2:2 | 10b | | | | X | X | X | X | X | X | X | X | | | | | |

Option GPS specifications

The following tables list the electrical and environmental characteristics of the GPS Synchronization and Timecode option.

GPS or GLONASS antenna input

| | |
|---|---|
| Input type | 50 Ω BNC; internally terminated |
| Input signal level minimum, typical | > 18 dB above ambient level Nominal gain of antenna minus cable loss, so a 35 dB antenna can have 17 dB cable loss at 1.575 GHz. |
| Return loss, typical | 8 dB at 1575 MHz Input has a narrow RF filter so it reflects most energy not near the GPS or GLONASS signal frequency. |
| DC antenna power output voltage, typical | 3.3 or 5 V at nominal load Sourced on Antenna input. May be enabled or disable. Approximately 12 Ω internal resistance so open circuit voltage is greater. Open circuit voltage is typically 3.8 V and 5.4 V. |
| DC antenna power output current, typical | 55 mA. |
| Antenna fault thresholds, typical | “OPEN” if <10 mA, “SHORT” if >100 mA. Else “Nominal” Antenna power state is displayed on UI in GPS status screen. Rear LED shows green flashing if open, green steady if nominal, red if shorted, and off if the power is not enabled. |

GPS timebase

| | |
|--|---|
| Reference modes | <p>User may select Internal or External lock to GPS, PTP or Video Reference.</p> <p>“Internal” sets the frequency to nominal.</p> <p>“GPS Signal” sets the timebase relative to the GPS or GLONASS input and aligns the frames to extrapolate back to the SMPTE Epoch.</p> <p>Video genlock sets timebase relative to incoming timebase.</p> |
| Operation when loses lock | <p>User may select Internal or holdover called “Stay Current Frequency”. “Internal” reverts to the nominal frequency as calibrated. “Stay Current Frequency” holds the last valid frequency from before the input was lost.</p> |
| Location modes (GPS mode only) | <p>User may select “Fixed” or “Mobile”.</p> <p>“Fixed” stores a well-averaged position and then uses that until set to reacquire. “Mobile” recalculates the position continuously and thus has a higher timebase variation.</p> |
| Stability when locked to GPS or GLONASS, typical ¹ | <p>Allan Deviation < 1×10^{-11}, measurement interval of 1, 10, or 100 sec in fixed position mode.</p> <p>Note that this is for fixed mode and is a function of base unit oscillator, satellite signal quality from antenna, and GPS functionality. For mobile mode, the Allan deviation is about $2E^{-10}$.</p> |
| Accuracy when locked to GPS or GLONASS | <p>± 1 part in 10^9 averaged over 30 sec. After 20 min warm up and in fixed mode.</p> <p>Long term stability is set by the GPS, but short term by the base unit.</p> |
| Accuracy in holdover mode, typical | <p>± 2 parts in 10^9 from recent valid lock frequency, Temp change of ± 5 °C. ± 10 parts in 10^9 for 0 to 50 °C.</p> <p>Translates to 10 ns of drift per 1 sec that is in holdover mode. This is a function of the base unit oscillator.</p> |
| Clean recovery holdover drift (GPS mode only) | <p>± 20 ms</p> <p>Maximum amount of timebase drift that can be corrected without disruption to video timing.</p> |
| Clean recovery holdover duration, typical (GPS mode only) | <p>35 days, must be in stable temperature environment and have warmed up for 20 minutes before holdover.</p> <p>Length of time that can be in stay current holdover mode and recover without disruption to syncs. Dependant on environment and base unit oven oscillator stability. Translates to 2 ns of drift per sec in holdover mode.</p> |
| Timing behavior when locked (GPS mode only) | <p>Displays “Locked” if within 150 ns of absolute time as detected by GPS or GLONASS signal.</p> |
| Frame timing accuracy in fixed position mode, typical (GPS mode only) | <p>Outputs of any two units are typically timed within 150 ns if both have good signal quality and the same cable delay from antenna to instrument.</p> <p>Frames Based on selected Epoch.</p> |

¹ Instruments with earlier Option GPS modules can receive only GPS signals. Instruments with later Option GPS modules can receive both GPS and GLONASS signals. (See page 76, How to determine which GPS receiver is installed in your instrument.)

| | |
|--|---|
| Frame behavior on relock, typical (GPS mode only) | <p>Selectable between Jam Phase, Fast Slew and Stay Legal.</p> <p>In Stay Legal mode, will stay in spec as slew with respect to frequency offset and drift rate spec. If in fast slew or stay legal mode, frames will slew back to the correct alignment via timebase offset without jumping.</p> <p>Recovery from drift may take a long time if configured for stay legal recovery (approximately 300 sec per line of drift at NTSC or PAL rates).</p> |
| Timebase offset during relock, typical (GPS mode only) | <p>For stay legal mode, limited to less than ± 0.2 ppm frequency offset, and limited to change less than 0.02 ppm/sec.</p> <p>Fast Slew has limits of ± 5 ppm offset and 0.5 ppm / sec.</p> |
| Time to acquire satellites and achieve specified stability, typical | <p>2 Minutes on boot up with warm oven, good satellite signal, and known position.</p> <p>Frames may jump on initial lock to establish correct relative positions.</p> |
| Definition of lock status figure of merit (GPS mode only) | <p>0 No signal</p> <p>1 Low signal</p> <p>2 Acquire Satellites</p> <p>3 Bad Position</p> <p>4 Acquire Position</p> <p>5 Adjust Phase</p> <p>6 Locked > Signal Quality ≤ 16</p> <p>7 Locked >> Signal Quality > 16</p> <p>8 Locked >>> Signal Quality > 26</p> <p>9 Locked >>>> Signal Quality > 42</p> <p>10 Locked >>>>> Signal Quality > 68</p> <p>11 Locked >>>>>> Signal Quality > 110</p> <p>Note that the receiver may take a few minutes to detect and display the signal.</p> |

Option PTP specifications

The following table lists the performance characteristics of Option PTP (Precision Time Protocol).

| | |
|--|---|
| Operating modes | In Internal, GPS lock, or Genlocked modes, may select one or two PTP masters. If locked to PTP then one PTP master can be enabled. Only one PTP function may be active on a given domain. |
| PTP Ethernet connection 1 | RJ45 8P8C connector supporting 10/100/1000 Base T. Has LEDs to indicate activity (Green) and rate (Orange if 1 G, yellow if 100 M). |
| PTP Ethernet connection 2 | SFP cage accepts 1 GE module. MSA standard. SFP modules are available as Opt. SX and LX. |
| Internet protocol version | IPv4 |
| Profiles supported | ST2059-2, AES67, General, AVB. Parameters may be adjusted within the range supported by each profile. |
| Master mode ST2059-2 synchronization metadata TLV support | Master outputs multicast SM TLV when active. Parameters set from the operating state of the instrument or from selections in the PTP menu. |
| Slave mode ST2059-2 synchronization metadata TLV support | Slave mode displays selected fields from the SM TLV in the status screens. |
| Communication mode support for the General AVB and AES67 profiles | Supports both Multicast and Unicast. Unicast requires grant negotiation, and the IP address of the master(s) must be entered in the slave AMT. |
| ST2059-2 profile master mode communication mode support | Supports: Multicast, Mixed, Mixed without grant negotiation, and Unicast. When the Master is in either Multicast, Mixed, or Mixed without negotiation mode, it will simultaneously support slaves in all of those modes. |
| ST2059-2 profile slave mode communication mode support | Supports Multicast, Mixed with negotiation, Mixed without negotiation and Unicast with negotiation. Unicast and Mixed without negotiation requires that the IP address of the master(s) be entered in the slave AMT. |
| AMT depth | Supports addresses for 8 masters. |
| Number of messages supported by master | Supports up to 8,192 messages a second. The maximum number of slaves depends on the message rate and communication mode. Unicast or mixed modes requiring negotiation are limited to a maximum of 1,024 slaves. |

Asymmetric delay correction Slave supports manual entry or a delay compensation value up to ± 20 us.

Timing offset, typical < 1 us for up to 7 hops of PTP compliant switches and < 500 ns of uncompensated asymmetric network delay.

Slave mode lock time at 8 messages per second, typical Three minutes if not previously locked.

PTP slave mode lock range ± 7.5 ppm.

Definition of lock status figure of merit

| Figure of merit | Description |
|-----------------|-----------------------------------|
| 0 | Waiting For Master |
| 1 | Adjusting PTP Frequency |
| 2 | Adjusting PTP Phase |
| 3 | Setting PTP Time |
| 4 | Unused - skipped |
| 5 | Adjust SPG Phase |
| 6 | Locked > With PTP lock > .25 |
| 7 | Locked >> With PTP lock > .5 |
| 8 | Locked >>> With PTP lock > .6 |
| 9 | Locked >>>> With PTP lock > .8 |
| 10 | Locked >>>>> With PTP lock > .9 |
| 11 | Locked >>>>>> With PTP lock > .95 |

Option SX specifications

The following table lists the electrical characteristics of the SFP module supplied with Option SX.

| | |
|--|--|
| Function | Hot pluggable Optical SFP MSA module. |
| Protocol | Gigabit Ethernet, 1.06 to 1.25 Gb. |
| Output wavelength, typical | 830 to 860 nm, 850 nm. |
| Receive wavelength, typical | 770 nm to 860 nm. |
| Optical output power, typical | -9.5 to -3 dBm. |
| Optical receiver sensitivity, typical | -17 to 0 dBm. |
| Supported distance, typical | 0 to 200 m for OM1, 0 to 500 m for OM2 |

Option LX specifications

The following table lists the electrical characteristics of the SFP module supplied with Option LX.

| | |
|------------------------------------|---|
| Function | Hot pluggable Optical SFP MSA module. |
| Protocol | Gigabit Ethernet, 1.06 to 1.25 Gb. Gigabit Ethernet, 1.06 to 1.25 Gb. |
| Output wavelength, typical | 1270 to 1355 nm, 1310 nm. |
| Receive wavelength, typical | 1270 nm to 1610 nm. |
| Fiber type | Single mode. |
| Optical, typical | |
| Output power | -11 to -3 dBm. |
| Receiver sensitivity | -19 to -3 dBm. |
| Supported distance | 0 to 2 km typical, up to 5 km possible depending on fiber. |

Performance verification

This section provides procedures to verify the performance and functionality of the SPG8000A base unit and units with options installed. Procedures that only apply to specific options will be noted as such.



CAUTION. *To prevent possible damage to a module or the base unit, always disconnect the power from the base unit before installing or removing a module.*

Preparation

Do the following before starting any of the following performance verification procedures:

Instrument warm-up period

The SPG8000A base unit and installed options must have had a warm-up period of at least 20 minutes before you start a performance verification procedure. Refer to the documentation provided with the test equipment for any preparation the test equipment may require.

Save the Power On default settings

Before you begin a performance verification procedure, you can save your required instrument settings in the Power On Default preset.

When the instrument settings are saved in the Power On Default preset, you can recall the settings after the performance verification procedure is completed by turning off and on the power (disconnect and connect the power cord).

Set the SPG8000A to Factory Mode

Most of the performance verification procedures require that the SPG8000A be restarted or rebooted in Factory Mode. There are two methods to put the SPG8000A into Factory Mode.

Restarting in Factory Mode. Use these steps to restart the SPG8000A in Factory Mode:

1. Remove power from the SPG8000A. (Disconnect the power cord.)
2. Press and hold the **Front Panel ENABLE** button. Continue holding the button while applying power (connecting the power cord). The message **SPG8000A Booting...** will display.
3. Continue to hold the **Front Panel** button until the message **SPG8000A Start up with Factory Mode** displays.
4. Release the **Front Panel** button.

Rebooting in Factory Mode. Use these steps to reboot the SPG8000A in Factory Mode, without removing power to the instrument:

1. Press and hold the **STATUS**, **ENTER**, and **Front Panel ENABLE** buttons simultaneously.
2. Continue holding the buttons until the message **SPG8000A Booting...** displays.
3. When the message **SPG8000A Booting...** displays, release the **STATUS** and **ENTER** buttons. Continue holding the **Front Panel ENABLE** button.
4. When the message **SPG8000A Start up with Factory Mode** displays, release the **Front Panel ENABLE** button.

Load the factory preset

1. Load the factory preset:
 - a. Press the **SYSTEM** button to select **SYSTEM : PRESET**.
 - b. Press the **ENTER** button to view the **SYSTEM : PRESET : RECALL** menu.
 - c. Press the left (◀) arrow button to select **Factory Default**.
 - d. Press the **ENTER** button to load the preset.
2. Press the **BACK** button to exit the Recall menu.

Diagnostics tests

This procedure verifies that the diagnostic tests pass. The diagnostics results should be verified for the base unit and for each option module, if installed.

Required equipment

No equipment is required for this procedure.

Test record Photocopy this table and use it to record the performance test results.

Table 13: SPG8000A Diagnostics test record

| Instrument Serial Number: Temperature: Date of Calibration: | | Certificate Number: RH %: Technician: | |
|---|---------------------------------|---|--------|
| Performance test | | | Result |
| Power On Diagnostics | | Pass/Fail | |
| PLL Locked | | | |
| | Main | Pass/Fail | |
| | SDI Flex - Option SDI only | Pass/Fail | |
| | SDI DDS Phase - Option SDI only | Pass/Fail | |
| Temperature | | | |
| | Main | Pass/Fail | |
| | CPU | Pass/Fail | |
| | REF - Option GPS only | Pass/Fail | |
| | SDI - Option SDI only | Pass/Fail | |
| | FPGA - Option SDI only | Pass/Fail | |
| Voltages | | Pass/Fail | |
| Fan Speed | | | |
| | Main | Pass/Fail | |
| | PS1 | Pass/Fail | |
| | PS2 - Option DPW only | Pass/Fail | |
| Power Supply 1 | | Pass/Fail | |
| Power Supply 2 - Option PDW only | | Pass/Fail | |
| GPS PHS DET RAMPS - Option GPS only | | Pass/Fail | |
| Module Memory | | Pass/Fail | |
| Front Panel Keys | | Pass/Fail | |
| PLL Range Check | | Pass/Fail | |
| Reference Infrastructure | | Pass/Fail | |

Diagnostics test procedure

1. Connect the power cord.

NOTE. *Install both power cords if Option DPW is installed.*

2. Check for any power-on error messages as the instrument starts. If present, they be displayed briefly during the power-on process. You can also view them from the instrument Web user interface on the System > Diagnostics page. (See the *SPG8000A Installation and Safety Instructions manual for information about the Web user interface.*)
3. Record **Pass** in the test record for **Power On Diagnostics** if no error messages are displayed. To note a failure, record the displayed error message in the test record.
4. Set the SPG8000A to Factory Mode. (See [Set the SPG8000A to Factory Mode](#) on page 31.)
5. Press the **REF** button.
6. Press the left (◀) arrow button to select **Internal** as the source.
7. Press the **ENTER** button.
8. Press the **SYSTEM** button.
9. Use the up (▲) arrow button to select **DIAGNOSTICS**.
10. Press the **ENTER** button.
11. Use the down (▼) arrow to step through all of the following diagnostic results. Some results are only available if the instrument has a specific option.
 - a. Tune: Displays 0 with no tuning signal. (Not in test record.)
 - b. Cal: Displays the most recent calibration data. (Not in test record.)
 - c. PLL: Verify that the following clock frequencies show locked (**Lk**) by pressing the right (▶) arrow button to view each of the clocks. Record **Pass** or **Fail** in the test record for each of the **PLL Locked** tests.
 - Main
 - SDI (Option SDI only)
 - SDI DDS (Option SDI only)

- d. **TEMPERATURE:** Verify that the following board temperature readings are normal (**OK**) by pressing the right (▶) arrow button to view each temperature. Record **Pass** or **Fail** in the test record for each of the **Temperature** tests.

NOTE. *Option GPS only: The REF temperature readout is N/A because there is no temperature sensor on the receiver.*

- Main
 - CPU
 - REF (Option GPS only)
 - SDI (Option SDI only)
 - FPGA (Option SDI only)
- e. **VOLTAGE:** Verify the following voltages are normal (**OK**) by pressing the right (▶) arrow button to view each of the voltages. Record **Pass** in the test record for **Voltages** if all voltages are normal. Otherwise, record **Fail** and list any failed voltages.

NOTE. *If you do not see a specific voltage on your instrument, it is because your instrument does not have the related hardware option installed.*

| | | | |
|---------------------|----------------|----------------------|-------------------------------|
| Main board: +5.0 V | Slot 1: +5.0 V | Slots 1 & 2: +8.0 AV | Ref board: +5.0 V |
| Main board: +3.3 V | Slot 2: +5.0 V | Slots 3 & 4: +8.0 AV | Ref board: +8.0 V |
| Main board: +2.5 V | Slot 3: +5.0 V | Slots 1 & 2: +5.0 AV | Ref board: -5.0 V relative to |
| Main board: +1.8 V | Slot 4: +5.0 V | Slots 3 & 4: +5.0 AV | +3.3 V |
| Main board: +1.5 V | Slot 1: +3.3 V | Fan +5 | SDI board: +1.2 V |
| Main board: +1.2 V | Slot 2: +3.3 V | RTC Battery | SDI board: +1.2 VA |
| Main board: -5.0 V | Slot 3: +3.3 V | PTP board 1: +1.2 V | SDI board: +3.3 V |
| Main board: +3.3 AV | Slot 4: +3.3 V | PTP board 1: +3.3 V | SDI board: +3.3 VA |
| | | PTP board 2: +1.69 V | SDI board: +1.5 V |
| | | | SDI board: +3.0 V |
| | | | SDI board: +1.8 V |
| | | | SDI board: Dref |

- f. **Fan Speed:** Verify that the following fan speeds are normal (**OK**) by pressing the left (◀) arrow button to view each fan speed. Record **Pass** or **Fail** in the test record for each of the **Fan Speed** tests.
- Main
 - PS1
 - PS2 - Option PDW only
- g. **Power Supply 1:** Verify that the temperature weighted hours (**Tmp Wtd**) and voltage (**V**) is normal (**OK**). Record **Pass** or **Fail** in the test record for **Power Supply 1**.

- h. Power Supply 2 (Option DPW only): Verify that the temperature weighted hours (**Tmp Wtd**) and voltage (**V**) is normal (**OK**). Record **Pass** or **Fail** in the test record for **Power Supply 2**.
 - i. GPS PHS DET RAMPS (Option GPS only): Press the right (**▶**) arrow button to verify that **Up A and B** and **Down A and B** are normal (**OK**). Record Pass or Fail in the test record for **GPS PHS DET RAMPS**.
- 12. Run the Module Memory test:
 - a. Press the down (**▼**) arrow to select **DIAGNOSTICS: RUN** and check that **Module Memory Tests** shows in the menu.
 - b. Press the **ENTER** button to run the test.
 - c. Verify that **All Installed Option(s)** memory passes.
 - d. Record **Pass** or **Fail** in the test record for **Module Memory**.
- 13. Run the Front Panel Key diagnostic test:
 - a. Press the right (**▶**) arrow button to select **Front Panel Key** from the **DIAGNOSTICS : RUN** menu.
 - b. Press the **ENTER** button to run the diagnostic.
 - c. Follow the instructions on the front panel display that will tell you to press specific buttons on the front panel. When the test is over, the display will tell you if the test was passed and then direct you to press the **BACK** button to exit the test.
 - d. Record the resulting **Pass** or **Fail** message in the test record for **Front Panel Keys**. If a failure occurs, record the error codes in the test record.
- 14. Run the PLL Range Check test:
 - a. Press the **ENTER** button to reenter the Diagnostics menu.
 - b. Press the down arrow until you see the **DIAGNOSTICS: RUN** menu.
 - c. Press the right (**▶**) arrow button to select **PLL Range Check**.
 - d. Press the **ENTER** button.
 - e. After the diagnostics testing is complete, note the PLL Low and High readings. Low should read -90×10^{-6} or lower. High should read $+90 \times 10^{-6}$ or higher.
 - f. Record **Pass** or **Fail** in the test record for **PLL Range Check**.
- 15. Run the Reference Infrastructure test:
 - a. Press the down (**▼**) arrow to select **DIAGNOSTICS: GPS IO TEST**.
 - b. Press the **ENTER** button to run the test.
 - c. Verify that the GPS IO test passes.
 - d. Record **Pass** or **Fail** in the test record for **Reference Infrastructure**.
- 16. Press the **BACK** button to exit the Run menu.

17. Cycle the instrument power to clear the effects of the memory diagnostics.
18. Set the SPG8000A to Factory Mode and load the factory preset settings. (See [Set the SPG8000A to Factory Mode](#) on page 31 and [Load the factory preset](#) on page 32.)

SPG8000A base unit performance verification

The following procedures verify the functionality of the SPG8000A base unit.

Required equipment The following table lists the required equipment for the base-unit procedures.

Table 14: Required equipment for SPG8000A base-unit performance verification

| Item | No. | Minimum requirement | Recommended equipment |
|--|-----|--|--|
| Frequency counter | 1 | Frequency range: 0.1 Hz to 10 MHz Precision: 10 digits or higher | Tektronix FCA3000 or equivalent |
| Frequency standard | 1 | 10 MHz Accuracy: 1×10^{-9} | Tektronix SPG8000 or SPG8000A locked to GPS, GLONASS or equivalent Spectracom/Pendulum 6689 |
| Waveform monitor | 1 | Composite and SDI input with external reference capability | WFM8300 with Option CPS or equivalent |
| Oscilloscope | 1 | Bandwidth: 200 MHz or higher | Tektronix TDS540D or TDS3054 |
| Digital voltmeter | 1 | | Keithley 2700 DMM |
| GPS or GLONASS receiver with video sync outputs | 1 | GPS or GLONASS input, 10M CW, NTSC, PAL, Tri-level sync, and SDI outputs | GPS7 and SDI7 module in a TG8000 or equivalent |
| 75 Ω BNC cable | 4 | Length: 42 inches | Tektronix part number 012-0074-00 |
| 75 Ω feed-through terminator ¹ | 1 | | Tektronix part number 011-0103-02 |
| 75 Ω precision terminator | 1 | | Tektronix part number 011-0102-03 |
| 75 Ω coaxial terminator | 2 | | Tektronix part number 011-0163-00 |
| BNC-to-Banana-Plug adapter | 1 | | Pomona model 1269 |
| BNC-to-test-clip adapter | 1 | Use to measure voltage across 600 Ω load resistor for LTC level procedure | |
| BNC T connector | 1 | Used to measure voltage on Black amplitude and offset test (SD) | |
| 15-pin DSUB male header with solder lugs | 1 | Used to assert GPI 1, 2, 3 inputs to restore presets | |

¹ The feed-through terminator is not required if the oscilloscope has an internal 75 Ω terminator.

Test record Photocopy this table and use it to record the SPG8000A base-unit performance test results.

Table 15: SPG8000A base-unit test record

| Instrument Serial Number: Temperature: Date of Calibration: | | | Certificate Number: RH %: Technician: | | |
|---|--------------|----------------|---|-------|-------|
| Performance test | -Min | +Max | Measured | Value | Value |
| Master Clock Accuracy | 9.999987 MHz | 10.0000013 MHz | | | |
| NTSC Functional Genlock and Timing | | | | Pass | Fail |
| PAL Functional Genlock and Timing | | | | Pass | Fail |
| 1080p24 Functional Lock and Timing | | | | Pass | Fail |
| Genlock ADC Bus Stuck | | | | Pass | Fail |
| Genlock ADC Bus Short | | | | Pass | Fail |
| Genlock Input | | | | | |
| Minimum Level | 1550 | 2550 | | | |
| Maximum Level | 2550 | 3550 | | | |
| Gain | 900 | 1100 | | | |
| LTC Positive Input Open Circuit Loop Back | | | | | |
| Minimum Level | 1250 | 1500 | | | |
| Maximum Level | 2200 | 2450 | | | |
| Gain | 850 | 1050 | | | |
| LTC Negative Input Open Circuit Loop Back | | | | | |
| Minimum Level | 1250 | 1500 | | | |
| Maximum Level | 2200 | 2450 | | | |
| Gain | 850 | 1050 | | | |
| LTC Positive Input Terminated Loop Back Gain | 400 | 525 | | | |
| LTC Negative Input Terminated Loop Back Gain | 400 | 525 | | | |
| Black Output Functional Test and Frame Pulse Test | | | | | |
| Black 1 | | | | | |
| PAL | | | | Pass | Fail |
| 1080 59.94i | | | | Pass | Fail |
| 1080 60i | | | | Pass | Fail |

| Instrument Serial Number: Temperature: Date of Calibration: | | | Certificate Number: RH %: Technician: | | |
|---|---------|---------|---|-------|-------|
| Performance test | -Min | +Max | Measured | Value | Value |
| Black 2 | | | | | |
| PAL | | | | Pass | Fail |
| 1080 59.94i | | | | Pass | Fail |
| 1080 60i | | | | Pass | Fail |
| Black 3 | | | | | |
| PAL | | | | Pass | Fail |
| 1080 59.94i | | | | Pass | Fail |
| 1080 60i | | | | Pass | Fail |
| Black Output Bit Integrity | | | | | |
| Black 1 | | | | | |
| Ramp | | | | Pass | Fail |
| Calibration Setting (AMPL. DAC number) | | | | | |
| Black 2 | | | | | |
| Ramp | | | | Pass | Fail |
| Calibration Setting (AMPL. DAC number) | | | | | |
| Black 3 | | | | | |
| Ramp | | | | Pass | Fail |
| Calibration Setting (AMPL. DAC number) | | | | Pass | Fail |
| Black Amplitude and Offset (SD) | | | | | |
| Black 1 | | | | | |
| 0 mV (offset) | - 40 mV | + 40 mV | | | |
| 700 mV | | | | | |
| Amplitude (difference) | 693 mV | 707 mV | | | |
| Black 2 | | | | | |
| 0 mV (offset) | - 40 mV | + 40 mV | | | |
| 700 mV | | | | | |
| Amplitude (difference) | 693 mV | 707 mV | | | |
| Black 3 | | | | | |
| 0 mV (offset) | - 40 mV | + 40 mV | | | |
| 700 mV | | | | | |
| Amplitude (difference) | 693 mV | 707 mV | | | |
| Trilevel Sync Output (HD) | | | | | |
| Black 1 | | | | | |

| Instrument Serial Number: Temperature: Date of Calibration: | | | Certificate Number: RH %: Technician: | | | |
|---|---|----------|---|----------|-------|-------|
| Performance test | | -Min | +Max | Measured | Value | Value |
| | Blanking Level | -50 mV | +50 mV | | | |
| | Sync Amplitude Plus | 294.0 mV | 306.0 mV | | | |
| | Sync Amplitude Minus | 294.0 mV | 306.0 mV | | | |
| Black 2 | | | | | | |
| | Blanking Level | -50 mV | +50 mV | | | |
| | Sync Amplitude Plus | 294.0 mV | 306.0 mV | | | |
| | Sync Amplitude Minus | 294.0 mV | 306.0 mV | | | |
| Black 3 | | | | | | |
| | Blanking Level | -50 mV | +50 mV | | | |
| | Sync Amplitude Plus | 294.0 mV | 306.0 mV | | | |
| | Sync Amplitude Minus | 294.0 mV | 306.0 mV | | | |
| Black Output Rise and Fall Time | | | | | | |
| Black 1, NTSC | | | | | | |
| | Fall Time of Falling Sync Edge | 120 ns | 150 ns | | | |
| Black 1, 1080 60i | | | | | | |
| | Rising Edge in the Middle of the Tri-level Sync | 40 ns | 60 ns | | | |
| Black 2, NTSC | | | | | | |
| | Fall Time of Falling Sync Edge | 120 ns | 150 ns | | | |
| Black 2, 1080 60i | | | | | | |
| | Rising Edge in the Middle of the Tri-level Sync | 40 ns | 60 ns | | | |
| Black 3, NTSC | | | | | | |
| | Fall Time of Falling Sync Edge | 120 ns | 150 ns | | | |
| Black 3, 1080 60i | | | | | | |
| | Rising Edge in the Middle of the Tri-level Sync | 40 ns | 60 ns | | | |
| Sine Amplitude | | | | | | |
| | Sine Amplitude | 1.35 V | 1.65 V | | | |
| LTC Level | | | | | | |

| Instrument Serial Number: Temperature: Date of Calibration: | | | Certificate Number: RH %: Technician: | | |
|---|-------|-------|---|-------|-------|
| Performance test | -Min | +Max | Measured | Value | Value |
| LTC 1 | | | | | |
| Maximum Positive Voltage | | | | | |
| Maximum Negative Voltage | | | | | |
| p-p Voltage (difference) | 4.5 V | 5.5 V | | | |
| LTC 2 | | | | | |
| Maximum Positive Voltage | | | | | |
| Maximum Negative Voltage | | | | | |
| p-p Voltage (difference) | 4.5 V | 5.5 V | | | |
| LTC 3 | | | | | |
| Maximum Positive Voltage | | | | | |
| Maximum Negative Voltage | | | | | |
| p-p Voltage (difference) | 4.5 V | 5.5 V | | | |
| LTC 4 | | | | | |
| Maximum Positive Voltage | | | | | |
| Maximum Negative Voltage | | | | | |
| p-p Voltage (difference) | 4.5 V | 5.5 V | | | |
| GPI Output Functional Test | | | | | |
| GPI 1 Out | 4.5 V | 5.5 V | | | |
| GPI 2 Out | 4.5 V | 5.5 V | | | |
| GPI Input Functional Test | | | | | |
| Program Time | | | | Pass | Fail |
| GPI Input Recall Test | | | | | |
| GPI Recall of Bit 1 | | | | Pass | Fail |
| GPI Recall of Bit 2 | | | | Pass | Fail |
| GPI Recall of Bit 3 | | | | Pass | Fail |
| 48 kHz Clock Output Level (CMOS compatible) | | | | | |
| 2.5 V DC Coupled into 75 Ω | | | | | |
| High | 2.1 V | 2.9 V | | | |

| | | | | | | |
|---|---------------------------------|--------|---|----------|-------|-------|
| Instrument Serial Number: Temperature: Date of Calibration: | | | Certificate Number: RH %: Technician: | | | |
| Performance test | | -Min | +Max | Measured | Value | Value |
| | Low | -0.2 V | +0.4 V | | | |
| | 1 V AC Coupled into 75 Ω | 0.9 V | 1.1 V | | | |

Master clock accuracy test

Perform this procedure to verify the accuracy of all video and audio related clocks, including black burst subcarriers and SDI rates. The following equipment is required for this test:

- Frequency counter
 - Frequency standard
 - 75 Ω BNC cable (2 required)
 - 75 Ω feed-through terminator
1. Use a 75 Ω BNC cable and the 75 Ω feed-through terminator to connect the **10 MHz / BLACK 3** connector to the INPUT A connector on the frequency counter as shown in the following figure.
 2. Use an appropriate cable to connect the frequency standard to the external reference input connector on the frequency counter.

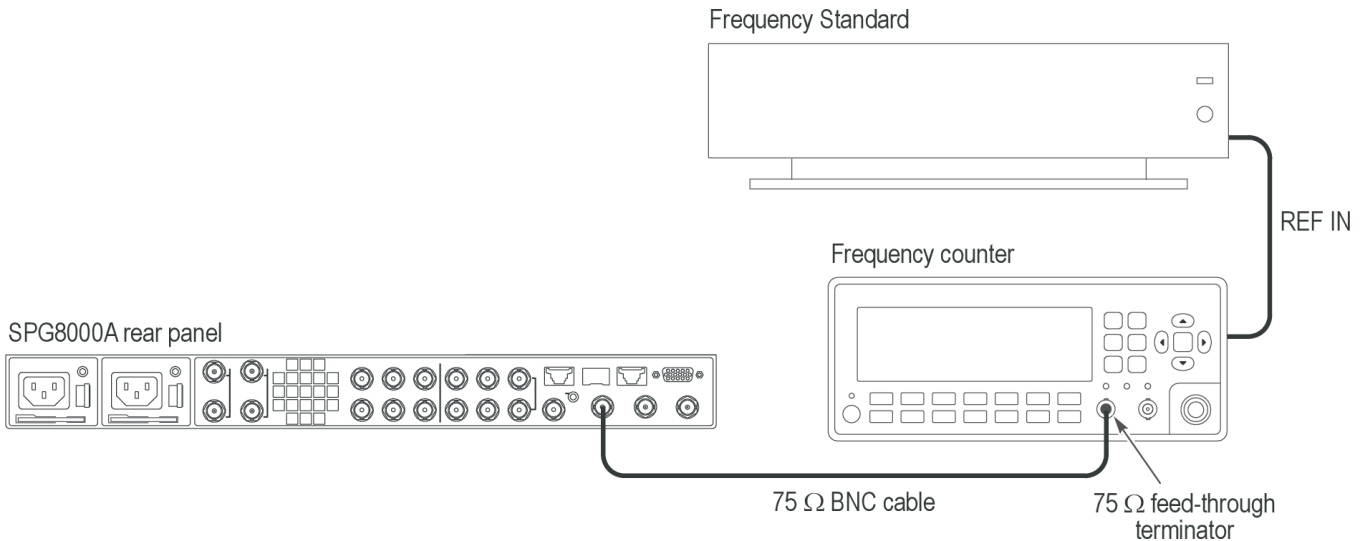

Figure 2: Setup to verify clock accuracy

3. Set the frequency counter to the external reference input.
4. Set the frequency counter to the frequency measurement mode (if necessary), and then set the Gate Time to 1 s.

5. Set the reference source on the SPG8000A to Internal as follows:
 - a. Press the **REF** button.
 - b. Press the left (◀) arrow button until **Internal** appears in the menu, and then press the **ENTER** button. The **INT** indicator below the Inputs button panel should turn green.
6. Output the CW 10 MHz calibration signal from the BLACK 3 output as follows:
 - a. Press the **BLACK** button until you see **BLACK 3** in the menu.
 - b. Press the left (◀) arrow button to select **CW 10 MHz**.
 - c. Press the **ENTER** button.
7. Set the frequency counter to trigger on the input, and then verify that the displayed frequency is within the range of 9.9999987 MHz to 10.0000013 MHz.
8. Record the measured frequency in the test record for **Master Clock Accuracy**.

Genlock function test

Perform the following procedure to check that the genlock and timing function is operating correctly. This test is divided into three parts: one part checks NTSC, one part checks PAL, and one part checks 1080p24. This test may be performed in normal or factory mode. (See [Set the SPG8000A to Factory Mode](#) on page 31.)

NTSC functional genlock and timing.

1. Use a 75 Ω BNC cable to connect the **BLACK 1** connector on the reference unit to the **REF** connector on the SPG8000A under test.
2. Use a second 75 Ω BNC cable to connect the **REF LOOP** connector of the SPG8000A to the **CMPST A** connector on the waveform monitor. Make sure to terminate the loop A input on the waveform monitor.

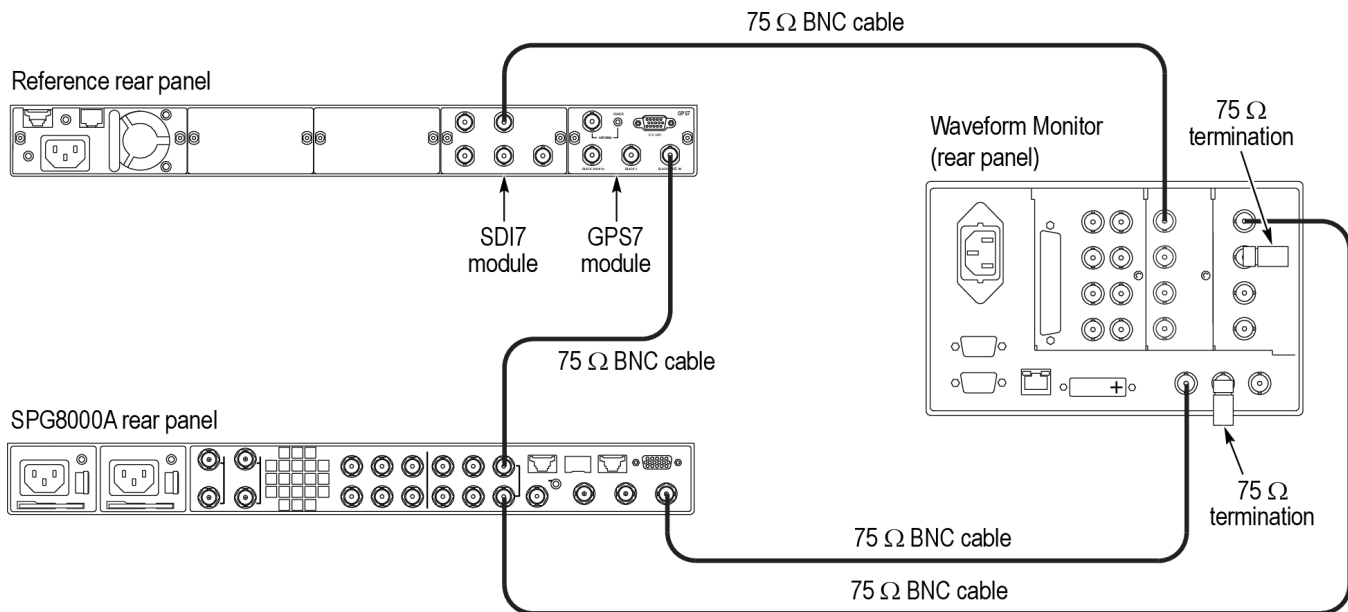

Figure 3: Setup for genlock test

3. Use a third 75 Ω BNC cable to connect the **SDI A** connector on the reference unit to one of the SDI inputs on the waveform monitor.
4. Use a fourth 75 Ω BNC cable to connect the **BLACK 1** connector on the SPG8000A under test to the REF IN connector of the waveform monitor. Make sure to terminate the reference loopthrough on the waveform monitor.
5. Press the composite input and the EXT REF buttons on the front panel of the waveform monitor to display the composite input relative to the reference signal.
6. Set the waveform monitor to 4-tile display mode and select the following displays: WFM, Vector, Timing (press the MEAS button), and Video Session (press the STATUS button).

NOTE. In the timing display, make sure the "relative to" window indicates "Analog DAC". If it does not, press and hold the MEAS button and correct it.

7. Load the factory default preset for both the reference unit and the SPG8000A under test. (See [Load the factory preset](#) on page 32.)
8. Set the reference unit source to Internal as follows:
 - a. Press the **MODULE** button until you see GPS7 in the menu.
 - b. Press the down (\blacktriangledown) arrow button until **REFERENCE** appears in the menu, and then press the **ENTER** button.

- c. Press the left (◀) arrow button until **Internal** appears in the menu as the source, and then press the **ENTER** button.
 - d. Press the **BACK** button to exit the menu.
9. Do the following steps to check that the **BLACK 1** output of the reference unit is set to NTSC Black Burst. (This should have been done automatically when the instrument was reset to factory default.)
 - a. Press the down (▼) arrow button until **SELECT OUTPUT** appears in the menu.
 - b. Press the left (◀) or right (▶) arrow until **BLACK 1** appears in the menu, and press the **ENTER** button.
 - c. You should see **SELECT FORMAT** in the menu. If you do not, press the down (▼) arrow button until it appears.
 - d. You should see **NTSC** on the menu.

If you do, the output is set correctly. Press the **BACK** button and proceed to step 10.

If you do not, press the left (◀) or right (▶) arrow button until **NTSC** appears, press the **ENTER** button. and then proceed to step 9.e.
 - e. You should see **Black Burst** on the menu. If you do not, press the left (◀) or right (▶) arrow button until **Black Burst** appears, and then press the **ENTER** button.
 - f. Press the **BACK** button twice to exit the menu.
10. Set the reference format of the SPG8000A under test to NTSC Burst as follows:
 - a. Press the **REF** button. You should see **REFERENCE: SOURCE**.
 - b. Press the right (▶) arrow button until you see **NTSC Burst** in the menu, and then press the **ENTER** button.
11. Set the **BLACK 1** output of the SPG8000A under test to NTSC as follows:
 - a. Press the **BLACK** button. You should see **BLACK 1 : FORMAT** on the menu display.
 - b. Press the right (▶) arrow button until you see **NTSC** in the menu, and then press the **ENTER** button.
12. Check the following and record **Pass** under **NTSC Functional Genlock and Timing** in the test record if all conditions are met. If any of these conditions are not met, record **Fail** in the test record.
 - Check that the EXT light on the front panel of the SPG8000A under test is a steady green.
 - Check that the Timing display on the waveform monitor reads 0 lines of offset and less than 0.1 μs of horizontal offset.
 - Check that the waveform in the Vector display on the waveform monitor is stable and not spinning.

PAL functional genlock and timing.

1. Set the BLACK 1 output of the reference GPS7 to PAL as follows:
 - a. Press the down (▼) arrow button until **SELECT OUTPUT** appears in the menu.
 - b. Press the left (◀) or right (▶) arrow until **BLACK 1** appears in the menu, and press the **ENTER** button.
 - c. You should see **SELECT FORMAT** in the menu. If you do not, press the down (▼) arrow button until it appears.
 - d. Press the right (▶) arrow until **PAL** appears in the menu, and then press the **ENTER** button.
 - e. Press the right (▶) arrow until **Black Burst** appears in the menu, and then press the **ENTER** button.
 - f. Press the **BACK** button twice to exit the menu.
2. Set the reference format of the SPG8000A under test to PAL Burst as follows:
 - a. Press the **REF** button. You should see **REFERENCE: SOURCE**.
 - b. Press the right (▶) arrow button until you see **PAL Burst** in the menu, and then press the **ENTER** button.
3. Set the BLACK 1 output of the SPG8000A under test to PAL as follows:
 - a. Press the **BLACK** button. You should see **BLACK 1 : FORMAT** on the menu display.
 - b. Press the right (▶) arrow button until you see **PAL** in the menu, and then press the **ENTER** button.
4. Check the following and record **Pass** under **PAL Functional Genlock and Timing** in the test record if all conditions are met. If any of these conditions are not met, record **Fail** in the test record.
 - Check that the EXT light on the front panel of the SPG8000A under test is a steady green.
 - Check that the Timing display on the waveform monitor reads 0 lines of offset and less than 0.1 μs of horizontal offset.
 - Check that the waveform in the Vector display on the waveform monitor is stable and not spinning.

NOTE. Proceed to the next step if you suspect the waveform monitor has indicated an inaccurate reading on the timing display. Otherwise, this procedure is now complete.

5. Some waveform monitors may not indicate exactly zero on the timing display for a correctly timed signal. If this is suspected, do the following steps:
 - a. Remove the termination on the waveform monitor reference input.
 - b. Connect a cable from that reference input to the CMPST B input on the waveform monitor.
 - c. Terminate the loopthrough on the CMPST B input.

- d. From the waveform monitor front panel, select the CMPST B input. The timing display should show zero because it is the same signal on the input and reference. If it is not shown as zero, do the following to remove any error in the timing measurement:
 - Make the timing tile active, then press and hold the MEAS button to bring up the menu.
 - Save a timing offset and then change the "relative to" to use the saved offset.
- e. Select the first composite input, and compare the timing of the unit under test to see if it is less than $0.1 \mu\text{s}$.

1080 24p functional lock and timing.

1. Set the SDI A output format of the reference module to 1080 24p as follows:
 - a. Press the **MODULE** button until you see SDI output you are using in the menu.
 - b. Press the **FORMAT** button.
 - c. Press the left (◀) arrow button until **1080 24p** appears, and then press the **ENTER** button.
 - d. Press the **BACK** button to exit the menu.
2. Set the reference unit **BLACK 1** to 1080 24p Tri-level Sync as follows:
 - a. Press the **MODULE** button until you see GPS7.
 - b. Press the down (▼) arrow button to view **BLACK 1** on the menu, and then press **ENTER**.
 - c. Press the down (▼) arrow button to view **SELECT FORMAT**.
 - d. Press the left (◀) or right (▶) arrow button to select 1080 24p, and then press the **ENTER** button.
3. Set the reference format of the SPG8000A unit under test to HD Tri-level Sync as follows:
 - a. Press the **REFERENCE** button.
 - b. You should see **SOURCE** in the menu. If you do not, press the down (▼) arrow button until it appears.
 - c. Press the right (▶) arrow button until **HD Tri-Level SYNC** appears, and then press the **ENTER** button.
4. Set the **BLACK 1** output of the SPG8000A unit under test to 1080 24p Tri-level Sync as follows:
 - a. Press the **BLACK** button until you see **BLACK 1-3 : HD TRI-LEVEL SYNC RATE** on the menu.
 - b. Press the right (▶) arrow button to select **Integer**, and then press the **ENTER** button.
 - c. Press the **BLACK** button until you see **BLACK 1** on the menu
 - d. Press the left (◀) arrow button until **1080 24p** appears, and then press the **ENTER** button.
5. Select the SDI input on the waveform monitor.
6. Set the timing display for “relative to Serial 0H” on the waveform monitor.
7. Check the following and record **Pass** under **1080 24p Functional Genlock and Timing** in the test record if all conditions are met. If any of these conditions are not met, record **Fail** in the test record.
 - Check that the EXT light on the front panel of the SPG8000A under test is a steady green.
 - Check that the Timing display on the waveform monitor reads 0 lines of offset and less than 0.1 μs of horizontal offset.

Genlock bit integrity and input gain test

Perform the following procedure to check the genlock bit integrity and input gain. This test is divided into two parts: one part checks bit integrity and one part checks genlock input gain.

This test should be performed in factory mode. (See [Set the SPG8000A to Factory Mode](#) on page 31.)

Genlock ADC bus stuck and short.

1. If you have just finished the previous procedure, disconnect the reference input of the SPG8000A under test from the waveform monitor composite input. The only connection needed is the one from the reference unit **BLACK 1** to the SPG8000A under test **REF** input.

Reference rear panel

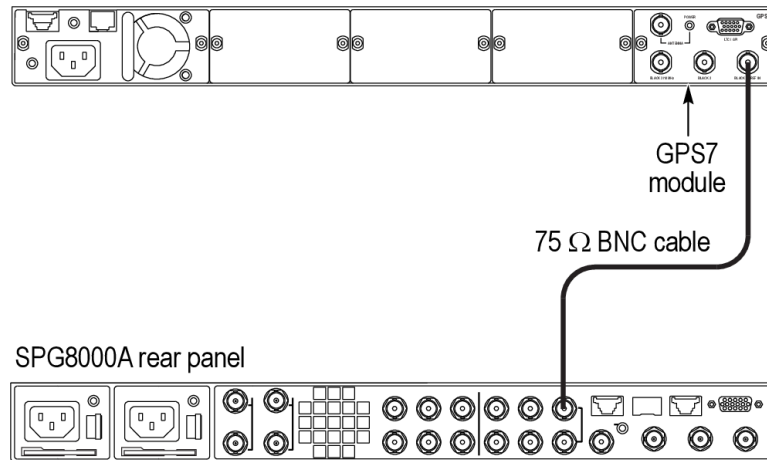
**Figure 4: Setup for genlock bit integrity test**

2. Set the **BLACK 1 / REF** output of the reference GPS7 to NTSC Black Burst with Field REF as follows:
 - a. Press the **MODULE** button until GPS7 appears.
 - b. Press the down (▼) arrow button until **SELECT OUTPUT** appears.
 - c. You should see **BLACK 1** in the menu. If you do not, press the left (◀) arrow button until it appears, and then press the **ENTER** button.
 - d. You should see **INPUT-OUTPUT** in the menu. If you do not, press the down (▼) arrow button until it appears.
 - e. You should see **OUTPUT** (if allowed) in the menu. If you do, press the **ENTER** button. If you do not, press the right (▶) arrow button until it appears in the menu, and then press the **ENTER** button.
 - f. Press the down (▼) arrow button until **SELECT FORMAT** appears in the menu and then press the **ENTER** button.
 - g. You should see **NTSC** in the menu. If you do, press the **ENTER** button. If you do not, press the right (▶) arrow button until it appears, and then press the **ENTER** button.
 - h. Press the right (▶) arrow button until **Black Burst with Field REF** appears, and then press the **ENTER** button.
 - i. Press the **BACK** button twice to exit the menu.
3. Set the REF source of the SPG8000A under test to NTSC Burst as follows:
 - a. Press the **REF** button.

- b. You should see **SOURCE** in the menu. If you do not, press the down (▼) arrow button until it appears.
 - c. Press the right (▶) arrow button until **NTSC Burst** appears, and then press the **ENTER** button.
4. Run the GPS ADC Bus stuck and short diagnostics on the SPG8000A under test as follows:
 - a. Press the **SYSTEM** button.
 - b. Press the up (▲) arrow button until you see **SYSTEM : DIAGNOSTICS**.
 - c. Press the **ENTER** button to enter the Diagnostics menu.
 - d. Press the down (▼) arrow button to select **GPS ADC BUS**.
 - e. View the results for the **Stuck** and **Short** bits.
5. Check the following and record Pass or Fail under *Genlock ADC Bus Stuck* and *Genlock ADC Bus Short* in the test record, depending on the following conditions:
 - If all bits in the *Stuck* field show a “-”, they all have activity. Record Pass in the test record.
 - If any bits in the *Stuck* field show an *H* or an *L*, then the bit is not moving. Record Fail in the test record.
 - If all bits in the *Short* field show a “-”, then none as shorted together. Record Pass in the test record.
 - If any bits in the *Short* field show an *S*, then record Fail in the test record.

Genlock input gain.

1. Press the down (▼) arrow button until you see **GENLOCK INPUT** in the Diagnostics menu.
2. Connect a 75 Ω terminator on the **REF LOOP** input on the SPG8000A under test.
3. Subtract the Min level from the Max level and compare the result to the limits in the test record. Record the Gain, Min, and Max values in the *Genlock input gain* test record.
4. Press the **BACK** button to exit the menu.

LTC input gain and impedance test

Perform the following procedure to check that the LTC input gain and impedance are functioning properly. This test is divided into three parts: the first part checks the LTC positive input open circuit loop back; the second part checks the LTC negative input open circuit loop back; the third part checks the LTC positive and negative terminated inputs loop back gain. This test should be performed in factory mode. (See [Set the SPG8000A to Factory Mode](#) on page 31.)

LTC positive input open circuit loop back.

1. If you have just finished the previous procedure, press the **LTC** button until **LTC 1** appears in the menu.
2. Press the up (▲) arrow button until **OUTPUT LEVEL** appears in the menu.
3. Press the right (▶) arrow button until the level shows **5.0 Volt**, and then press the **ENTER** button.
4. Press the down (▼) arrow button until **LTC1 LOOPBACK** appears in the menu.
5. Press the right arrow button (▶) until **Enable** appears in the menu, and then press the **ENTER** button.
6. View the diagnostics as follows:
 - a. Press the **SYSTEM** button.
 - b. Press the up (▲) arrow button until **DIAGNOSTICS** appears in the menu, and then press the **ENTER** button.
 - c. Press the up (▲) or down (▼) arrow buttons until **LTC POS INPUT** appears.
7. Record the Min and Max levels in *LTC Positive input open circuit loop back* in the test record.
8. Subtract the Min level from the Max level and record the result in *LTC positive open circuit loop back gain* in the test record.

LTC negative input open circuit loop back.

1. Press the right (▶) arrow button until **LTC NEG INPUT** appears in the Diagnostics menu
2. Record the Min and Max levels in *LTC Negative input open circuit loop back* in the test record.
3. Subtract the Min level from the Max level and record the result in *LTC negative open circuit loop back gain* in the test record.

LTC positive and negative terminated inputs loop back gain

1. Connect a breakout cable to the LTC / GPI input of the SPG8000A under test.

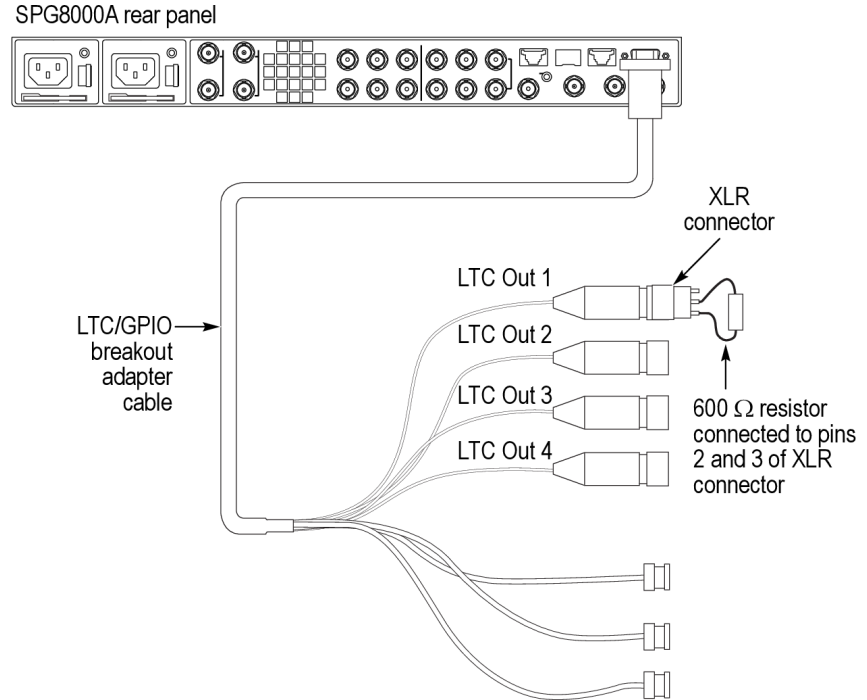

Figure 5: Setup for LTC input gain and impedance test

2. Connect a 600 Ω XLR load with meter access to LTC1 end of the breakout cable.
3. Press the left (\blacktriangleleft) arrow button to view the **LTC POS INPUT** diagnostic display again.
4. Note the Min level and Max level and then subtract the Min level from the Max level and record the result in *LTC Positive input terminated loop back Gain* in the test record.
5. Press the right (\blacktriangleright) arrow button until **LTC NEG INPUT** appears in the Diagnostics menu.
6. Note the Min level and Max level and then subtract the Min level from the Max level and record the result in *LTC Negative input terminated loop back Gain* in the test record.

Black output functional test and frame pulse test

Perform the following procedure to check that the Black signal output and internal frame pulse signals are functioning properly.

If you have just finished the previous test, disconnect all the cables from the unit under test before beginning this procedure.

1. Connect an SDI signal from the reference unit, like one from an SDI7 module, to the SDI input of a video monitor, and select that input as the active input on the waveform monitor.

NOTE. You can use any HD signal. For example, HD 1080i59, 1080i50, or 1080p24.

2. Connect a cable from the BLACK 1 output on the SPG8000A under test to the external reference input of the video monitor, and terminate the loop through on the monitor with a 75 Ω terminator.

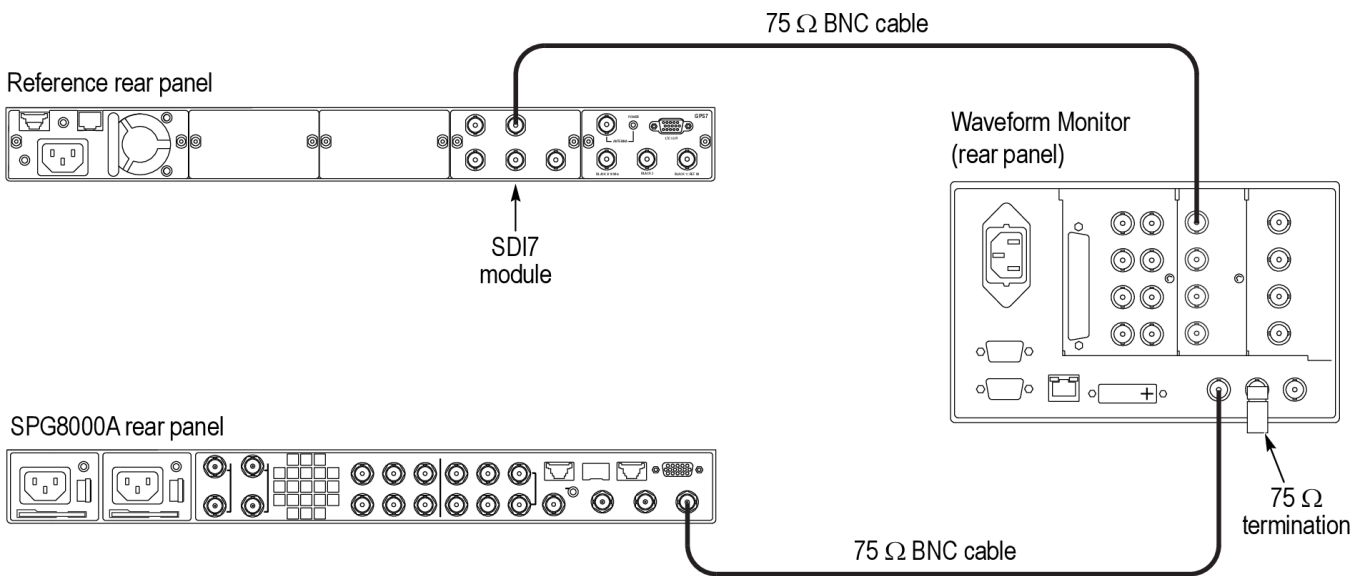

Figure 6: Setup for black output and frame pulse test

3. Press the **EXT REF** button on the video monitor.
4. Set the reference source on the SPG8000A to internal:
 - a. Press the **REF** button. You should see **REFERENCE : SOURCE** on the menu.
 - b. Use the left (◀) or right (▶) arrow button to select **Internal**.
 - c. Press the **ENTER** button.
5. Set **BLACK 1** to PAL on the SPG8000A as follows:
 - a. Press the **BLACK** button. You should see **BLACK 1 : FORMAT** on the menu.
 - b. Use the left (◀) or right (▶) arrow button to select **PAL**.
 - c. Press the **ENTER** button.
6. Check that the video monitor shows PAL as the reference input.

7. Record the result in the test record.
8. Set the **BLACK 1** output of the SPG8000A under test to 1080 59.94i as follows:
 - a. Press the **BLACK** button until you see **BLACK 1-3 : HD TRI-LEVEL SYNC RATE** on the menu.
 - b. Press the right (▶) arrow button to select **Non-Integer**, and then press the **ENTER** button.
 - c. Press the **BLACK** button until you see **BLACK 1** on the menu
 - d. Press the left (◀) arrow button until **1080 59.94i** appears, and then press the **ENTER** button.
9. Check that the video monitor shows a 1080 59.94i signal on the reference input.
10. Record the result in the test record.
11. Set the **BLACK 1** output of the SPG8000A under test to 1080 60i as follows:
 - a. Press the **BLACK** button until you see **BLACK 1-3 : HD TRI-LEVEL SYNC RATE** on the menu.
 - b. Press the right (▶) arrow button to select **Integer**, and then press the **ENTER** button.
 - c. Press the **BLACK** button until you see **BLACK 1** on the menu
 - d. Press the left (◀) arrow button until **1080 60i** appears, and then press the **ENTER** button.
12. Check that the video monitor shows a 1080 60i signal on the reference input.
13. Record the result in the test record.
14. Disconnect the cable from the **BLACK 1** connector of the SPG8000A under test and connect it to the **BLACK 2** connector of the SPG8000A under test.
15. Repeat steps 5 through 13 for the **BLACK 2** output.
16. Disconnect the cable from the **BLACK 2** connector of the SPG8000A under test and connect it to the **BLACK 3** connector of the SPG8000A under test.
17. Repeat steps 5 through 13 for the **BLACK 3** output.

Black output bit integrity test

Perform the following test to insure that all the bits in the black generators are working correctly. This test should be performed in factory mode. (See [Set the SPG8000A to Factory Mode](#) on page 31.)

1. Connect a cable from the **BLACK 1** output of the SPG8000A under test to the CMPST A input on the video monitor, and terminate the loopthrough with a 75 Ω terminator.

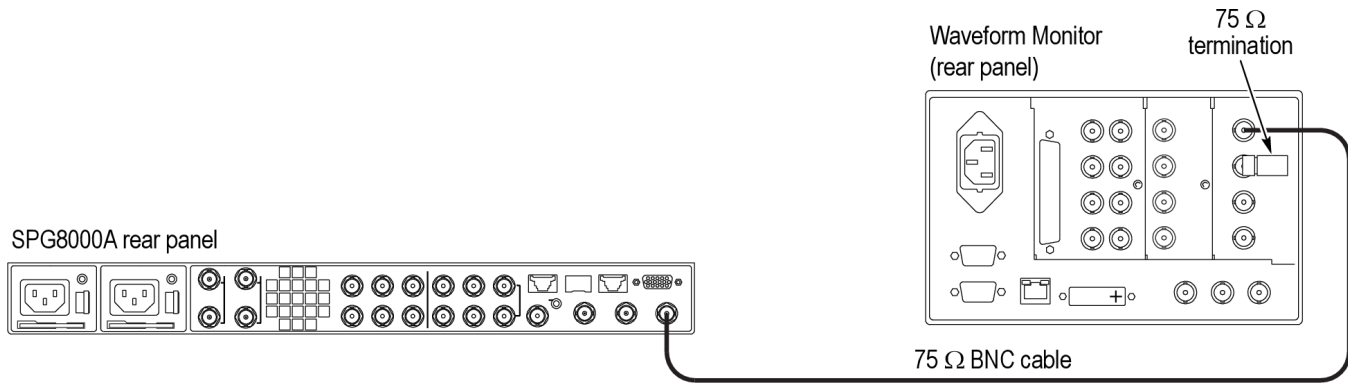

Figure 7: Setup for black output bit integrity test

2. Activate the waveform monitor composite input.
3. Press the **BLACK** button on the SPG8000A until you see **BLACK 1 : FORMAT**.
4. Use the left (◀) or right (▶) arrow button to select **NTSC**.
5. Press the **ENTER** button.
6. Use the up (▲) arrow button to select **CALIBRATION**.
7. Press the **ENTER** button to select **Amplitude Calibration**.

NOTE. Write down the calibration setting (AMPL. DAC number) in case you need to restore it later.

8. Press the right (▶) arrow until you see the **Ramp HPF** ramp signal.
9. Look at the three ramps on the waveform monitor display. The larger of the two ramps should each have 16 equal steps.

NOTE. View the waveform display in full screen mode for easiest viewing.

10. Use the Gain function on the waveform monitor to expand the signal to 10X.
11. Now check that the shallowest ramp has 16 equal steps.
12. Record Pass or Fail in the test record.
13. Check that the RAMP HPF calibration setting has not changed. If it has, then restore the original value.
14. Press the **BACK** button to exit the Calibration menu.
15. Repeat this procedure for the Black 2 and Black 3 outputs of the SPG8000A.

Black amplitude and offset test (SD)

Perform this procedure to check that Black signal output amplitude and offset for SD signals are adjusted to within specification. This test should be performed in factory mode. (See *Set the SPG8000A to Factory Mode* on page 31.)

1. Connect the BNC-to-Banana-plug adapter to the voltmeter.
2. Connect the BNC T to the adapter.
3. Connect a 75 Ω precision terminator to one end of the BNC T connector.
4. Connect a 75 Ω BNC cable to the other end of the BNC T connector.
5. Connect the other end of the cable to the **BLACK 1** output on the SPG8000A.

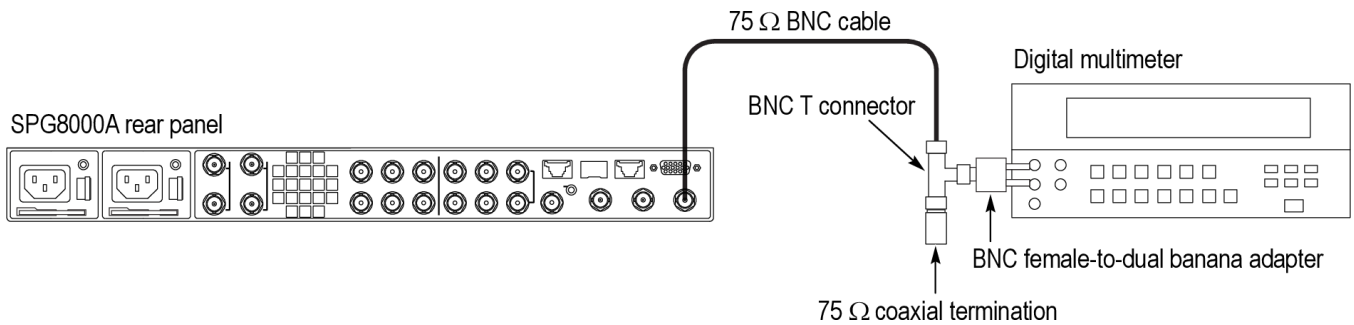

Figure 8: Setup for Black amplitude and offset test (SD)

6. Set the Black 1, Black 2, and Black 3 signals to NTSC as follows:
 - a. Press the **BLACK** button on the SPG8000A until you see **BLACK 1: FORMAT** on the menu.
 - b. Use the left (\blacktriangleleft) or right (\blacktriangleright) arrow button to select **NTSC**.
 - c. Press the **ENTER** button.
 - d. Repeat the previous substeps for the **BLACK 2** and **BLACK 3** outputs.
7. Press the **BLACK** button until you see **BLACK 1** on the menu.
8. Use the up (\blacktriangle) arrow button to select **CALIBRATION**.
9. Press the **ENTER** button to select **Amplitude Calibration**.

NOTE. Write down the calibration setting (AMPL. DAC number) in case you need to restore it later.

10. Check that the calibration mode signal is 0 V on the SPG8000A display. This value is displayed in parentheses after the AMPL. DAC number.
11. Record the voltmeter reading in the test record. This is the offset value.
12. Use the right (\blacktriangleright) arrow to select the 700 mV level.
13. Record the value in the test record.
14. Calculate the difference between the 700 mV and 0 mV signal levels and record this in the test record.
15. Check that the calibration setting has not changed. If it has, then restore the original value.

16. Press the **BACK** button to exit the calibration menu for the Black 1 signal.
17. Repeat step 7 through 16 for Black 2 and Black 3.

Trilevel sync output test (HD)

Perform this procedure to check that Black 1 through 3 output amplitude and offset for HD Trilevel sync signals are adjusted to within specification. This test should be performed in factory mode. (See [Set the SPG8000A to Factory Mode](#) on page 31.)

1. Connect the **BLACK 1** output of the SPG8000A to the oscilloscope and terminate the input with a 75 Ω feedthrough terminator.

NOTE. Make sure that the oscilloscope input is set to 1 M Ω mode if you are using the feedthrough terminator.

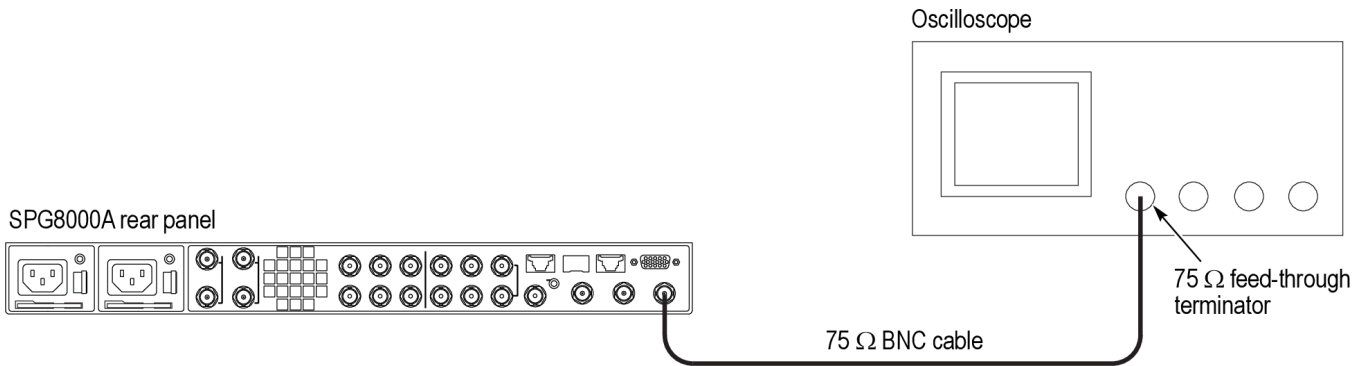

Figure 9: Setup for trilevel sync output test and black output rise and fall time test

2. Select the **1080 59.94i** HD sync signal for Black 1, Black 2, and Black 3 outputs on the SPG8000A as follows:
 - a. Press the **BLACK** button until you see **BLACK 1-3 : HD TRI-LEVEL SYNC RATE** in the menu.
 - b. Press the left (**◀**) arrow button to select **Non-Integer**, and press the **ENTER** button.
 - c. Press the **BLACK** button until you see **BLACK 1 : FORMAT**.
 - d. Press the left (**◀**) or right (**▶**) arrow button to select **1080 59.94i**, and then press **ENTER**.
 - e. Repeat the previous substeps for the **BLACK 2** and **BLACK 3** outputs.
3. Set the oscilloscope settings as follows:

| Control | Setting |
|-----------------|------------|
| Vertical | 100 mV/div |
| Vertical offset | 0 V |
| Horizontal | 500 ns/div |

| Control | Setting |
|---------------------|-------------|
| Horizontal position | Center |
| Input | CH1 |
| Trigger | CH1 |
| Trigger level | -150 mV |
| Trig position | 50% |
| Trig slope | Rising Edge |
| Acquire mode | Sample |

4. Verify that the blanking level is within the range of +50 mV to -50 mV.
5. Record the measured value in the test record for *Blanking Level*.
6. Change the oscilloscope vertical scale to 10 mV/div.
7. Align the blanking level with the center graticule line on the oscilloscope.
8. Change the oscilloscope vertical offset to 300 mV.
9. Verify that the high level of the signal (sync amplitude plus) is within the range of +0.6 div to -0.6 div to the center graticule (except for ringing of the rising edge).
10. Record the measured value in the test record for *Sync amplitude plus*.
11. Change the oscilloscope vertical offset to -300 mV.
12. Verify that the low level of the signal (sync amplitude minus) is within the range of +0.6 div to -0.6 div to the center graticule (except for ringing of the falling edge).
13. Record the measured value in the test record for *Sync amplitude minus*.
14. Set the vertical offset to 0 V and change the vertical gain to 100 mV/div.
15. Repeat steps 4 through 13 for the Black 2 and Black 3 outputs, making sure to move the cable to the connector of the output you are testing.

Black output rise and fall time test

Perform this procedure to check that the Black output rise and fall time meet specifications.

Use the same setup as the previous test. (See [Figure 9: Setup for trilevel sync output test and black output rise and fall time test](#) on page 58.)

1. Connect the **BLACK 1** output of the SPG8000A to the oscilloscope and terminate the input with a 75 Ω feedthrough terminator.

NOTE. Make sure that the oscilloscope input is set to 1 M Ω mode if you are using the feedthrough terminator.

2. Press the **BLACK** button until you see the **BLACK 1 : FORMAT** menu.
3. Use the left (◀) or right (▶) arrow button to select **NTSC**.
4. Press the **ENTER** button.

5. Press the **BLACK** button until you see **BLACK 1-3 : HD TRI-LEVEL SYNC RATE** in the menu.
6. Press the left (◀) arrow button to select **Integer**, and press the **ENTER** button.
7. On the oscilloscope, set the trigger slope to negative and then measure the 10 % to 90 % fall time of the falling sync edge.
8. Record the result in the test record.
9. Press the **BLACK** button until you can see the **BLACK 1 : FORMAT** menu.
10. Use the right (▶) arrow to select a **1080 60i** signal format.
11. Press the **ENTER** button.
12. On the oscilloscope, set the trigger slope to positive and then measure the 10% to 90% rise time of the rising edge in the middle of the Tri-level Sync.
13. Record the result in the test record.
14. Repeat the above steps for the Black 2 and Black 3 outputs, skipping steps 5 and 6.

Sine amplitude test Perform this procedure to check the sine amplitude.

1. Connect the **BLACK 3** output on the SPG8000A to the oscilloscope, and terminate the input with a 75 Ω feed-through terminator.

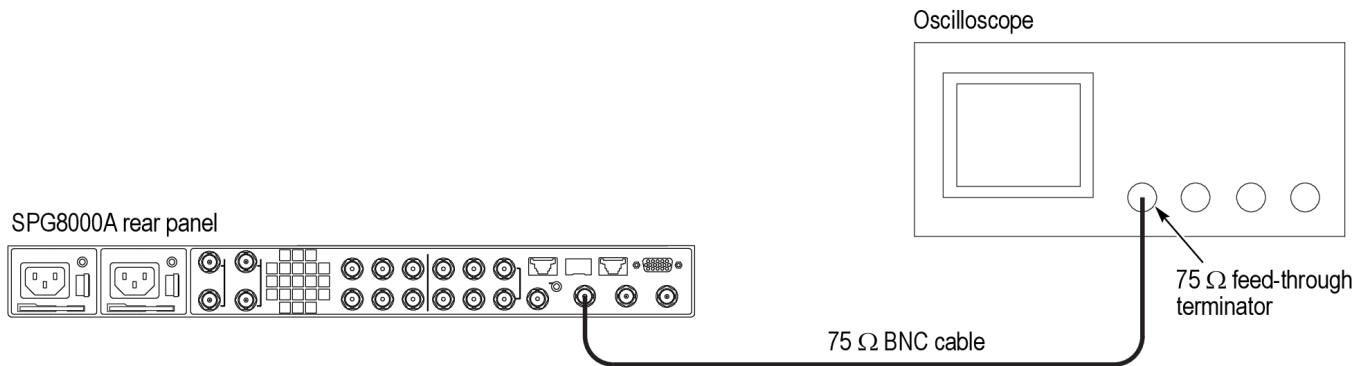

Figure 10: Setup for sine amplitude test

2. Press the **BLACK** button until **BLACK 3 : FORMAT** appears.
3. Use the left (◀) arrow button to select **CW 10 MHz**.
4. Press the **ENTER** button.
5. Measure the amplitude of the sine wave on the oscilloscope.
6. Record the result in the test record.

LTC level test

Perform this test to check the LTC levels are within limits. This test should be performed in factory mode. (See [Set the SPG8000A to Factory Mode](#) on page 31.)

1. Create an LTC load with voltmeter access by soldering a 600 Ω resistor to pins 2 and 3 of the female XLR connector.
2. Connect the LTC load with voltmeter access to the LTC 1 connector on the LTC/GPIO breakout adapter cable.
3. Connect the LTC/GPIO adapter cable to the DSUB connector on the rear of the module.
4. Connect a BNC-to-test clip adapter to the voltmeter using a BNC-to-Banana adapter and BNC cable.
5. Attach the clips to either side of the 600 Ω resistor.

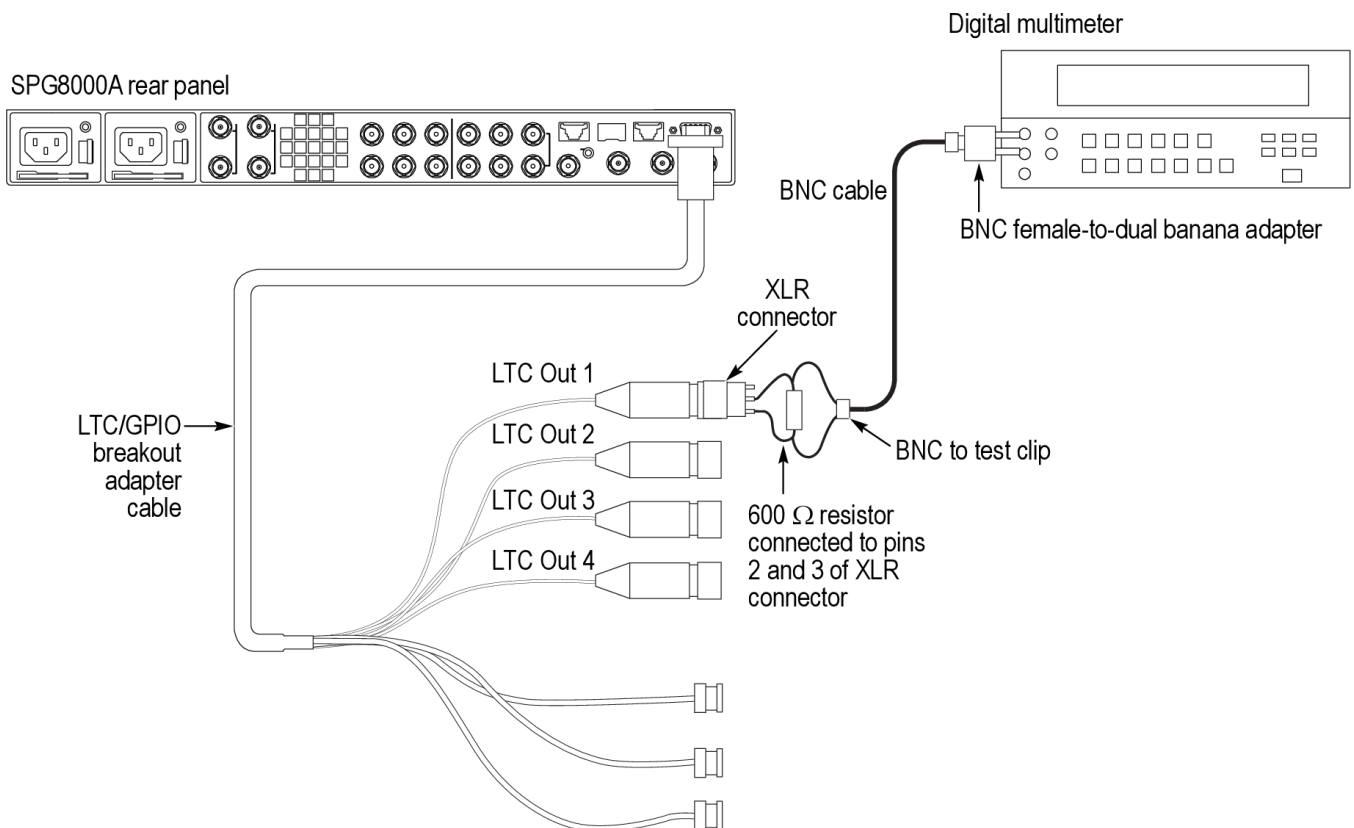

Figure 11: Setup for LTC level test

6. Press the **LTC** button to select **LTC 1**.
7. Press the right (**▶**) or left (**◀**) arrow button to view **Output (if allowed)** on the menu.
8. Press the **ENTER** button.
9. Press the down arrow button to select **LTC 1 : SOURCE**.
10. Press the right (**▶**) arrow button to select **Program Time**, and then press the **ENTER** button.
11. Use the up (**▲**) arrow button to select **CALIBRATION**.

12. Use the left (◀) arrow button to select **Set maximum positive voltage**.
13. Press the **ENTER** button.
14. Record the voltage result in the test record.
15. Use the left (◀) arrow button to select **Set maximum negative voltage**.
16. Press the **ENTER** button.
17. Record the voltage result in the test record.
18. Solve for the difference between the two voltages you recorded to get the p-p voltage.
19. Record the result in the test record.
20. Repeat this procedure for LTC 2, LTC 3, and LTC 4, skipping steps 7 and 8.

GPI output functional test

This procedure checks that the GPI output is functioning properly.

1. Use a 75 Ω cable to connect the **BLACK 1** output of the reference unit to the **REF** input connector of the SPG8000A under test, and terminate the reference **LOOP** connector.
2. Set the **BLACK 1** output of the reference unit to NTSC as follows:
 - a. Press the **MODULE** button to select the GPS7 module.
 - b. Press the down (▼) arrow button until **SELECT OUTPUT** appears in the menu.
 - c. Use the left (◀) or right (▶) arrow button until **BLACK 1** appears in the menu, and then press the **ENTER** button.
 - d. You should see **SELECT FORMAT** in the menu. If you do not, press the down (▼) arrow button until it appears.
 - e. You should see **NTSC** on the menu. If you do not, press the left (◀) or right (▶) arrow button until **NTSC** appears, and then press the **ENTER** button.
 - f. You should see **Black Burst** on the menu. If you do not, press the left (◀) or right (▶) arrow button until **Black Burst** appears, and then press the **ENTER** button.
3. Set the **REF** input of the SPG8000A under test to NTSC as follows:
 - a. Press the **REF** button on the SPG8000A.
 - b. Press the up (▲) arrow button until you see **SOURCE**.
 - c. Use the left (◀) or right (▶) arrow button to select **NTSC Burst**.
 - d. Press the **ENTER** button.
 - e. Check that the **EXT** indicator light on the front panel is green and stable.

4. Connect the **GPI/LTC** connector of the SPG8000A to the voltmeter as follows:
 - a. Connect the BNC-to-Banana-plug adapter to the voltmeter.
 - b. Connect the LTC/GPIO breakout adapter cable to the **GPI/LTC** DSUB on the back of the SPG8000A.
 - c. Connect the GPI 1 connector on the breakout cable to the BNC-to-Banana-plug adapter.

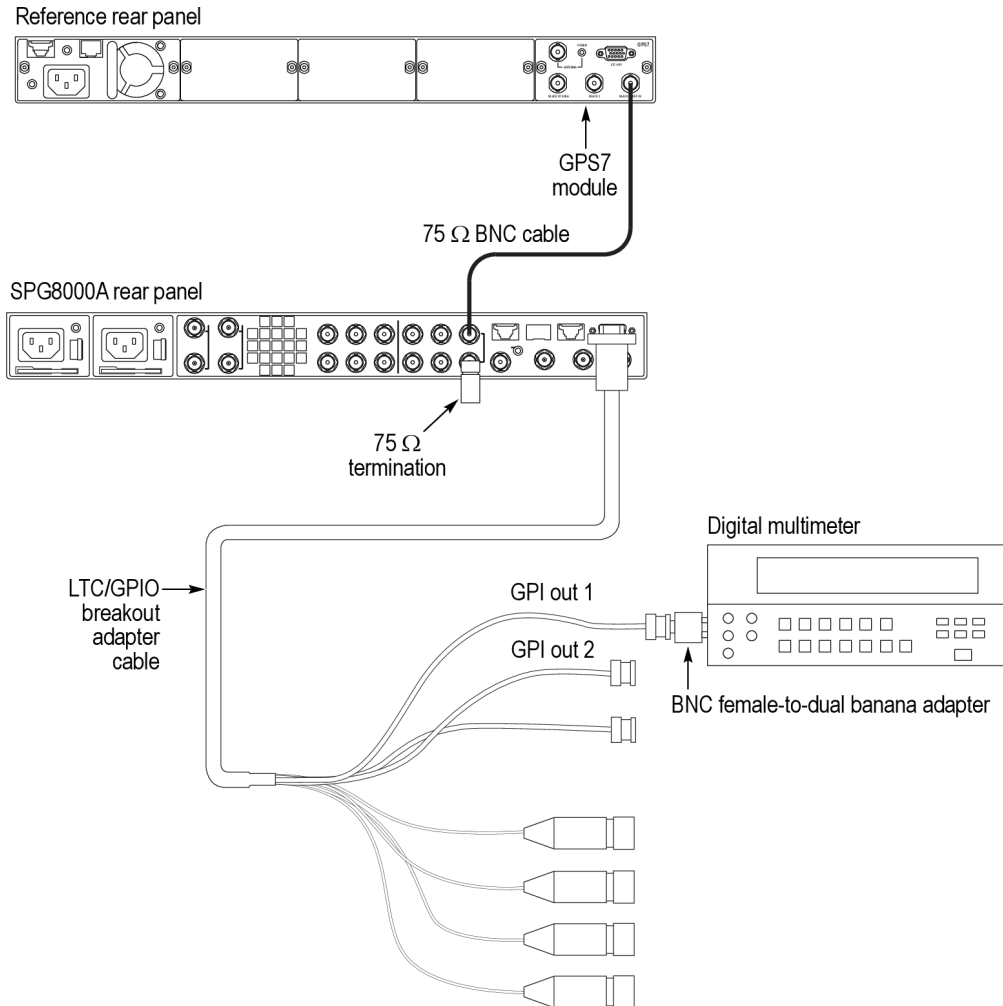

Figure 12: Setup for GPI output test

5. Configure the GPI 1 output to be asserted on unlock as follows:
 - a. Press the **SYSTEM** button on the SPG8000A under test.
 - b. Use the down (▼) arrow button to select **GPI**, and then press the **ENTER** button.
 - c. Use the down (▼) arrow button to select **GPI : OUTPUT 1**, and then press the **ENTER** button.

- d. Use the down (▼) arrow button to select **LOCK ERROR**.
 - e. Press the right (▶) arrow button to select **Enable**, and then press the **ENTER** button.
6. Check that the voltage on the GPI 1 output measures between 4.5 V and 5.5 V.
7. Record the result in the test record.
8. Disconnect the reference input to the SPG8000A under test. After 15 seconds, check that the GPI 1 output is below 0.5 V.
9. Record the result in the test record.
10. Reconnect the cable from the reference unit to the reference input on the SPG8000A under test.
11. Repeat steps 5 through 10 for the GPI 2 output.

GPI input functional test

This procedure checks that the GPI input is functioning correctly. If you have just completed the previous test, do the following:

1. Configure the GPI input of the SPG8000A to reset the program time:
 - a. Press the **SYSTEM** button.
 - b. Use the down (▼) arrow button to select **GPI**, and then press the **ENTER** button.
 - c. Use the down (▼) arrow button until you see **INPUT TRIGGER**.
 - d. Press the right (▶) arrow button until you see **Reset Program Time**, and then press the **ENTER** button.
2. Check that the reference source is set to Internal as follows:
 - a. Press the **REF** button.
 - b. Use the right (▶) or left (◀) arrow button to view **Internal**.
 - c. Press the **ENTER** button.
3. Press the **STATUS** button.
4. Press the down (▼) arrow button to select **TIME : Internal**.
5. Press the right (▶) arrow button to view the Program Time, and then record the value.
6. Attach a 75 Ω terminator to the GPI input for 2 seconds, and then remove it.
7. Look at the program time now and compare it to the program time you wrote down before. The time on the display should have reset to the default start time of 00:00:00:00 and now be counting again.

8. Record Pass or Fail in the test record.

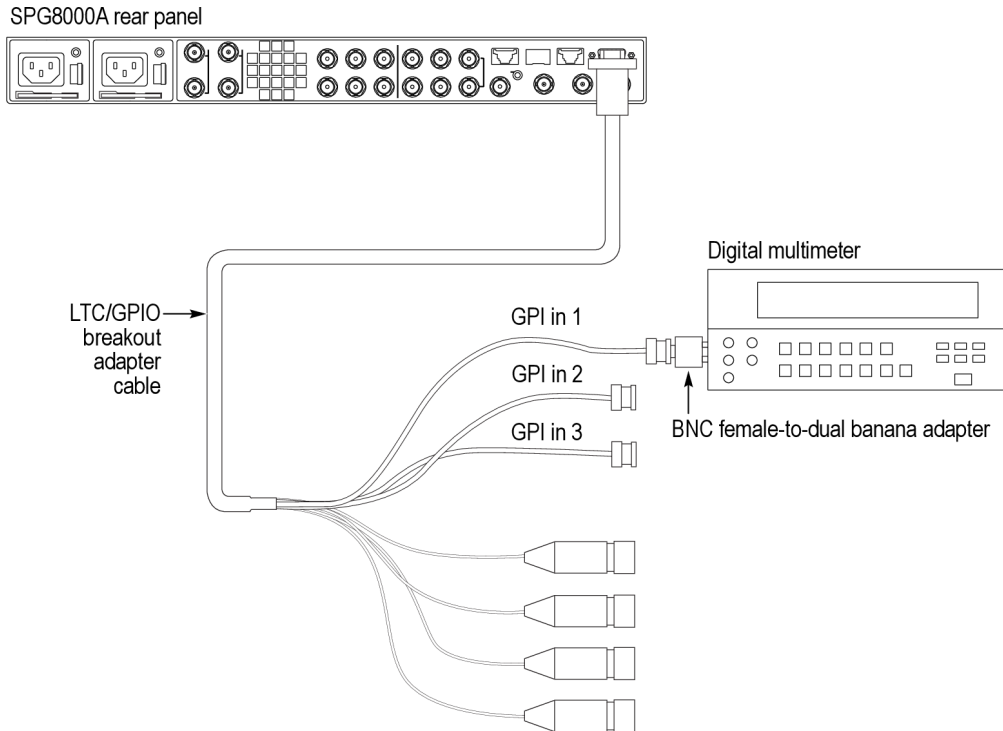

Figure 13: Setup for GPI input functional test

GPI input recall test

Perform this procedure to insure that the GPI inputs can trigger a preset restore on presets 1 to 7. If you have just completed the previous test, do the following. This test should be performed in factory mode. (See [Set the SPG8000A to Factory Mode](#) on page 31.)

1. On the 15-pin header, solder a three inch wire to each of the following pins: 3, 4, and 11.
2. Connect the 15-pin header to the **GPI/LTC** connector on the rear of the SPG8000A.
3. Press the **SYSTEM** button.
4. Touch the wire from pin 4 to the chassis of the SPG8000A.
5. Check that the display on the SPG8000A shows + **Factory Check: Preset-1** +.
6. Record **Pass** or **Fail** for **GPI recall of Bit 1** in the test record.
7. Touch the wire from pin 11 to the chassis of the SPG8000A.
8. Check that the display on the SPG8000A shows + **Factory Check: Preset-2** +.
9. Record **Pass** or **Fail** for **GPI recall of Bit 2** in the test record.
10. Touch the wire from pin 3 to the chassis of the SPG8000A.

11. Check that the display on the SPG8000A shows + **Factory Check: Preset-4** +.
12. Record **Pass** or **Fail** for **GPI recall of Bit 3** in the test record.

48 kHz clock output level test

Perform the following procedure to verify that 48 kHz clock signal is output correctly from the 48 kHz **WORD CLK** connector: This test is divided into two sections: the first section tests the output at 2.5 V, and the second section tests the output at 1 V AC. The following equipment is required for this test:

- Oscilloscope
- 75 Ω BNC cable
- 75 Ω feed-through terminator

2.5 V DC coupled into 75 Ω.

1. On the SPG8000A, set the Word Clock output to 5 V (DC):
 - a. Press the **AES** button.
 - b. Press the up (▲) arrow button until you see **AES WORD CLOCK OUTPUT**.
 - c. Press the right (▶) arrow button until you see **5 Volt (DC)**, and then press the **ENTER** button.
2. Use the 75 Ω BNC cable and the 75 Ω feed-through terminator to connect the 48 kHz **WORD CLK** connector to the oscilloscope CH1 input as shown in the following figure.

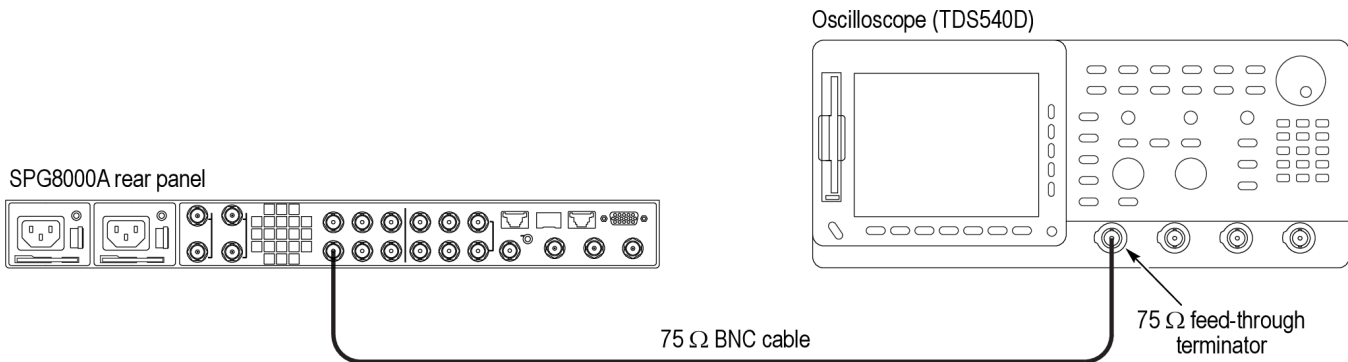

Figure 14: Setup for 48 kHz clock output test

3. Set the oscilloscope settings as follows:

| Control | Setting |
|---------------|------------|
| Vertical | 500 mV/div |
| Horizontal | 10 μs/div |
| Record Length | 1000 |
| Acquire menu | Sample |

| Control | Setting |
|------------------|--------------|
| Trigger position | 50% |
| Trigger slope | Rising Edge |
| Trigger level | +0.5 V |
| Input impedance | 1 M Ω |
| Measure | Amplitude |

4. Measure the low and high levels and record the results in the test record.

1 V AC coupled into 75 Ω

1. On the SPG8000A, set the Word Clock output to 1 V (AC):
 - a. Press the **AES** button.
 - b. Press the up (**▲**) arrow button until you see **AES WORD CLOCK OUTPUT**.
 - c. Press the right (**►**) arrow button until you see **1 Volt (AC)**, and then press the **ENTER** button.
2. Set the oscilloscope settings as follows:

| Control | Setting |
|------------------|-----------------|
| Vertical | 500 mV/div |
| Horizontal | 200 μ s/div |
| Record Length | 1000 |
| Acquire menu | Sample |
| Trigger position | 50% |
| Trigger slope | Rising Edge |
| Trigger level | +0.0 V |
| Input impedance | 1 M Ω |
| Measure | Amplitude |

3. Measure the level and record the result in the test record.

Option AG performance verification

The following procedure verifies the functionality of the Option AG serial digital audio and silence outputs.

NOTE. *The procedure in this section only applies to SPG8000A units with Option AG installed.*

Required equipment The following table lists the required equipment for the following procedure.

Table 16: Required equipment for Option AG performance verification

| Item | Qty. | Minimum requirements | Recommended equipment |
|-------------------------------------|------|------------------------------|--|
| Digital Audio Monitor | 1 | | Tektronix AMM768 or WFM8300 with Option AUD or equivalent |
| Oscilloscope | 1 | Bandwidth: 200 MHz or higher | Tektronix TDS540D or TDS3054 |
| 75 Ω BNC cable | 1 | Length: 42 inches | Tektronix part number 012-0074-00 or Belden 1694 or MarkerTek 1694-B-B-3 |
| 75 Ω feed-through terminator | 1 | | Tektronix part number 011-0103-02 |

Test record Photocopy this table and use it to record the performance test results.

Table 17: SPG8000A Option AG test record

| Instrument Serial Number: Temperature: Date of Calibration: | | | Certificate Number: RH %: Technician: | | |
|---|----------|----------|---|-------|-------|
| Performance test | Minimum | Measured | Maximum | Value | Value |
| AES/EBU Serial Digital Audio Output Signal Amplitude | | | | | |
| 1+2 | 900 mV | | 1100 mV | | |
| 3+4 | 900 mV | | 1100 mV | | |
| 5+6 | 900 mV | | 1100 mV | | |
| 7+8 | 900 mV | | 1100 mV | | |
| DARS Output Level | 900 mV | | 1100 mV | | |
| AES/EBU Bar Graph Levels | | | | | |
| 1+2 | -20 dBfs | | | | |
| 3+4 | -20 dBfs | | | | |
| 5+6 | -20 dBfs | | | | |
| 7+8 | -20 dBfs | | | | |
| DARS Bar Graph Level | | | | Pass | Fail |

Procedures Be sure you have performed the performance verification preparation before proceeding. (See [Performance verification](#) on page 31.)

You can perform performance verification procedures individually, if desired.

**AES-EBU serial digital
audio output level test**

Perform the following procedure to verify that serial digital audio signals are output correctly from the 1+2, 3+4, 5+6, 7+8, and DARS connectors. The procedure is divided into two sections: the first checks the AES output signal amplitude levels using an oscilloscope, and the second checks the AES bar level outputs using a digital audio monitor.

AES/EBU output signal amplitude level.

1. Use the 75 Ω BNC cable and the 75 Ω feed-through terminator to connect the AES 1+2 connector on the SPG8000A to the oscilloscope CH1 input as shown in the following figure.

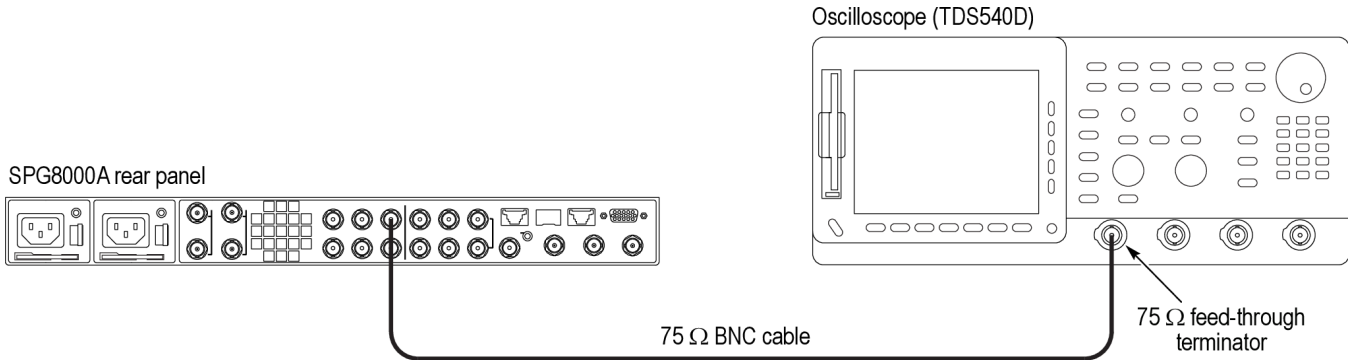

Figure 15: Oscilloscope setup for serial digital audio outputs test

2. Set the oscilloscope settings as follows:

| Control | Setting |
|------------------|-------------|
| Vertical | 200 mV/div |
| Horizontal | 100 ns/div |
| Acquire | Sample |
| Trigger position | 50% |
| Trigger slope | Rising Edge |
| Input impedance | 1 MΩ |
| Measure | Amplitude |

3. Load the factory default preset. (See [Load the factory preset](#) on page 32.)
4. Use the oscilloscope to measure that the signal amplitude is within the range of 900 mV to 1100 mV for the AES 1+2 channel.
5. Record the measured value for AES 1+2 in the test record.
6. Use the oscilloscope to measure that the signal amplitude is within the range of 900 mV to 1100 mV for the remaining AES channels as follows:
 - Change the BNC cable connection from the AES 1+2 connector to the AES 3+4 connector and record the measured value for AES 3+4 in the test record.
 - Change the BNC cable connection from the AES 3+4 connector to the AES 5+6 connector and record the measured value for AES 5+6 in the test record.
 - Change the BNC cable connection from the AES 5+6 connector to the AES 7+8 connector and record the measured value for AES 7+8 in the test record.

- Change the BNC cable connection from the AES 7+8 connector to the DARS connector and record the measured value for DARS in the test record.
7. Change the BNC cable connection from the DARS connector to the AES 1+2 connector.

AES/EBU bar graph levels.

1. Disconnect the BNC cable and the 75 Ω terminator from the oscilloscope CH1 input connector, and then connect the BNC cable to the A IN 1,2 BNC connector on the digital audio monitor rear panel as shown in the following figure.

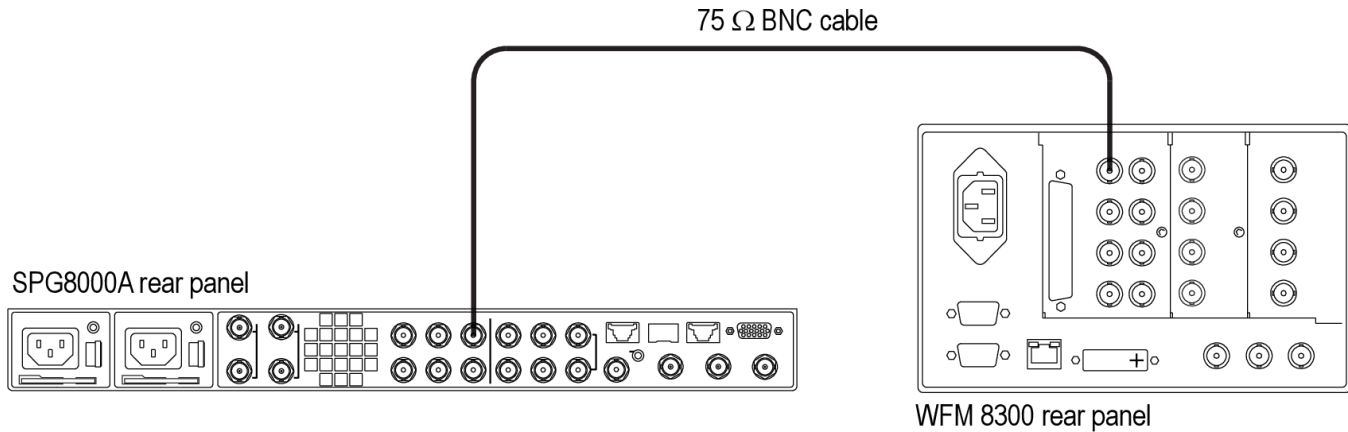

Figure 16: Audio monitor setup for serial digital audio outputs test

2. Check that no CRC errors are displayed on Channel 1 and Channel 2 of the digital audio monitor.
3. Verify that the digital audio monitor bar graphs show both Channel 1 and Channel 2 at -20 dBfs.
4. Record the measured value for 1+2 in the *AES/EBU bar graph levels* section of the test record.
5. Use the digital audio monitor to verify that the bar graphs show each channel at -20 dBfs for the remaining AES channels as follows:
 - On the SPG8000A, change the BNC cable connection from the AES 1+2 connector to the AES 3+4 connector and record the measured value for AES 3+4 in the test record.
 - On the SPG8000A, change the BNC cable connection from the AES 3+4 connector to the AES 5+6 connector and record the measured value for AES 5+6 in the test record.
 - On the SPG8000A, change the BNC cable connection from the AES 5+6 connector to the AES 7+8 connector and record the measured value for AES 7+8 in the test record.
6. Change the BNC cable connection from the AES 7+8 connector to the DARS connector and verify that MUTE is displayed and that the bar levels are at the bottom of the bar graph.
7. Record Pass or Fail in the *DARS bar graph level* section of the test record.

Option BG performance verification

The following procedures verify the functionality of the Option BG black generator outputs.

NOTE. All of the procedures in this section only apply to SPG8000A units with Option BG installed.

Required equipment The following table lists the required equipment for the following procedures.

Table 18: Required equipment for Option BG performance verification

| Item | Qty. | Minimum requirement | Recommended equipment |
|--|------|---|---|
| Oscilloscope | 1 | Bandwidth: 200 MHz or higher | Tektronix TDS540D or TDS3054 |
| Digital voltmeter | 1 | ?? | ?? |
| 75 Ω BNC cable | 1 | Length: 42 inches | Tektronix part number 012-0074-00 or MarkerTek 1694-B-B-3 |
| BNC T connector | 1 | Used to measure voltage on Black amplitude and offset test (SD) | |
| BNC female-to-dual-banana-plug adapter | 1 | | Pomona model 1269 |
| 75 Ω feed-through terminator | 1 | | Tektronix part number 011-0055-02 |
| 75 Ω precision terminator | 1 | | Tektronix part number 011-0102-03 |

Test record Photocopy this table and use it to record the performance test results.

Table 19: SPG8000A Option BG test record

| Instrument Serial Number: Temperature: Date of Calibration: | | | Certificate Number: RH %: Technician: | | |
|---|---------|------------------------|---|----------|----------|
| Performance test | | | Minimum | Measured | Maximum |
| Tri-Level Sync Output | | | | | |
| Blanking Level | | | | | |
| | BLACK 4 | | -50 mV | | +50 mV |
| | BLACK 5 | | -50 mV | | +50 mV |
| Sync Amplitude plus | | | | | |
| | BLACK 4 | | 294.0 mV | | 306.0 mV |
| | BLACK 5 | | 294.0 mV | | 306.0 mV |
| Sync Amplitude minus | | | | | |
| | BLACK 4 | | 294.0 mV | | 306.0 mV |
| | BLACK 5 | | 294.0 mV | | 306.0 mV |
| Black Output and Offset (SD) | | | | | |
| Sync Amplitude | | | | | |
| | BLACK 4 | | | | |
| | | 0 mV (offset) | -40 mV | | +40 mV |
| | | 700 mV | | | |
| | | Amplitude (difference) | 693.0 mV | | 707.0 mV |
| | BLACK 5 | | | | |
| | | 0 mV (offset) | -40 mV | | +40 mV |
| | | 700 mV | | | |
| | | Amplitude (difference) | 693.0 mV | | 707.0 mV |
| Composite Output | | | | | |

| Instrument Serial Number: Temperature: Date of Calibration: | | Certificate Number: RH %: Technician: | | |
|--|--|---|----------|----------|
| Performance test | | Minimum | Measured | Maximum |
| Luminance Offset and Gain (Measured on DC signals) | | | | |
| CMPST 1 | | | | |
| 0 mV (offset) | | -40 mV | | +40 mV |
| 700 mV | | | | |
| Amplitude (difference) | | 693.0 mV | | 707.0 mV |
| Blanking level | | | | |
| CMPST 2 | | | | |
| 0 mV (offset) | | -40 mV | | +40 mV |
| 700 mV | | | | |
| Amplitude (difference) | | 693.0 mV | | 707.0 mV |
| Blanking level | | | | |
| Composite Luma to Chroma Gain Match (Measured on PAL 75% Color Bars with 100% White) | | | | |
| CMPST 1 Luma to Cyan bar match | | -6.7 mV | | +6.7 mV |
| CMPST 2 Luma to Cyan bar match | | -6.7 mV | | +6.7 mV |

Procedures The following procedure checks that the Option BG outputs are operating correctly. Be sure you have performed the performance verification preparation before proceeding. (See [Performance verification](#) on page 31.)

Trilevel sync outputs test Perform the following procedure to verify the blanking level and sync amplitude of trilevel sync signals. The following equipment is required for the test:

- Oscilloscope
- 75 Ω BNC cable
- 75 Ω feed-through terminator

1. Use the 75 Ω BNC cable and the 75 Ω feed-through terminator to connect the **BLACK 4** connector on the SPG8000A to the oscilloscope CH1 input as shown in the following figure.

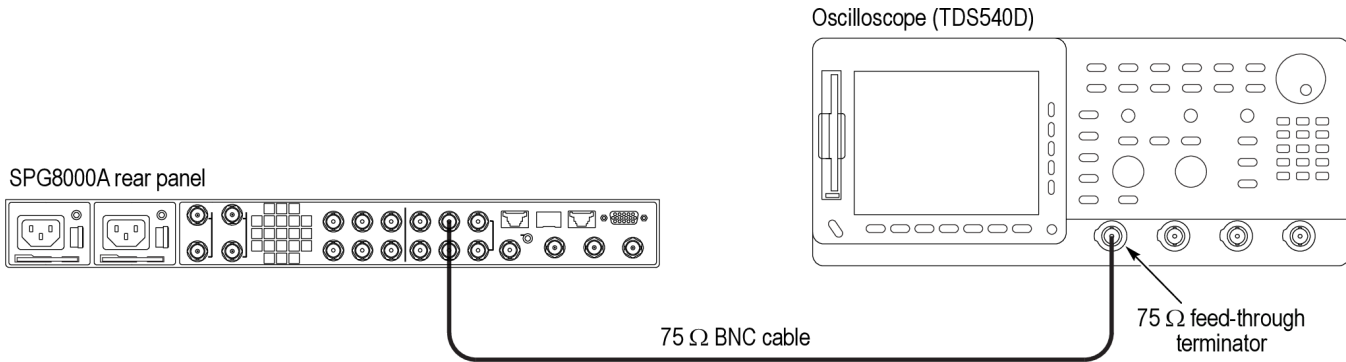

Figure 17: Setup for tri-level sync and black (PAL) output tests

2. Load the factory default preset. (See [Load the factory preset](#) on page 32.)
3. Select the **1080 59.94i** HD sync signal for BLACK 4 output on the SPG8000A as follows:
 - a. Press the **BLACK** button until you see **BLACK 4 : FORMAT**.
 - b. Press the left (**◀**) or right (**▶**) arrow button to select **1080 59.94i**, and then press **ENTER**.
 - c. Repeat this step for the **BLACK 5** output.
4. Set the oscilloscope settings as follows:

| Control | Setting |
|---------------------|-------------|
| Vertical | 50 mV/div |
| Vertical offset | 0 V |
| Horizontal | 500 ns/div |
| Horizontal position | Center |
| Trig position | 50% |
| Trig level | -150 mV |
| Trig slope | Rising Edge |
| Acquire menu | Sample |

5. Verify that the blanking level is within the range of +50 mV to -50 mV.
6. Record the measured value in the test record for *Tri-level Sync Output Blanking Level*.
7. Change the oscilloscope vertical scale to 10 mV/div.
8. Align the blanking level with the center graticule line on the oscilloscope.
9. Change the oscilloscope vertical offset to 300 mV.

10. Verify that the high level of the signal (sync amplitude plus) is within the range of +0.6 div to –0.6 div to the center graticule (except for ringing of the rising edge).
11. Record the measured value in the test record for *Sync Amplitude plus*.
12. Change the oscilloscope vertical offset to –300 mV.
13. Verify that the low level of the signal (sync amplitude minus) is within the range of +0.6 div to –0.6 div to the center graticule (except for ringing of the falling edge).
14. Record the measured value in the test record for *Sync Amplitude minus*.
15. Set the vertical offset to 0 V and change the vertical gain to 50 mv/div.
16. Change the BNC cable connection from the **BLACK 5** connector to the **BLACK 4** connector on the SPG8000A and repeat steps 5 through 14.

Black output and offset test (SD)

Perform this procedure to check that Black signal output amplitude and offset for SD signals are adjusted to within specification. This test should be performed in factory mode. (See [Set the SPG8000A to Factory Mode](#) on page 31.)

1. Connect the BNC-to-Banana-plug adapter to the voltmeter.
2. Connect the BNC T to the adapter.
3. Connect a 75 Ω precision terminator to one end of the BNC T connector.
4. Connect a 75 Ω BNC cable to the other end of the BNC T connector.
5. Connect the other end of the cable to the **BLACK 4** output on the SPG8000A.

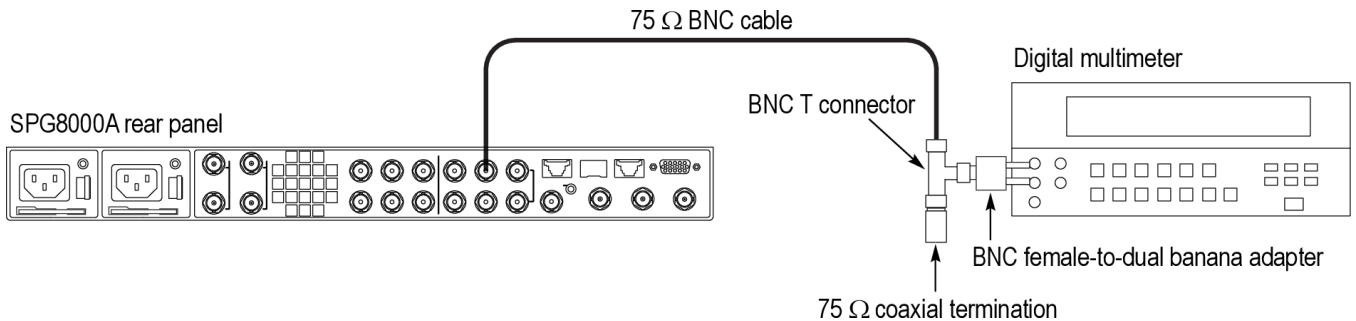

Figure 18: Setup for Black amplitude and offset test (SD) – Option BG

6. Set the Black 4 and Black 5 signals to NTSC as follows:
 - a. Press the **BLACK** button on the SPG8000A until you see **BLACK 4 : FORMAT** on the menu.
 - b. Use the left (◀) or right (▶) arrow button to select **NTSC**.
 - c. Press the **ENTER** button.
 - d. Repeat the previous substeps for the **BLACK 5** output.
7. Press the **BLACK** button until you see **BLACK 4** on the menu.

8. Use the up (▲) arrow button to select **CALIBRATION**.
9. Use the right (▶) arrow button to select **DAC Offset (0 V DC)**.
10. Press the **ENTER** button.
11. Record the voltmeter reading in the test record. This is the offset value.
12. Use the right (▶) arrow to select **DAC Gain (700 mV DC)**.
13. Press the **ENTER** button.
14. Record the value in the test record.
15. Calculate the difference between the 700 mV and 0 mV signal levels and record this in the test record.
16. Repeat steps 7 through 15 for Black 5.

Composite offset and gain test

Perform this procedure to check that Composite signal output offset and gain for SD signals are adjusted to within specification. This test should be performed in factory mode. (See [Set the SPG8000A to Factory Mode](#) on page 31.)

1. Connect the BNC-to-Banana-plug adapter to the voltmeter.
2. Connect the BNC T to the adapter.
3. Connect a 75 Ω precision terminator to one end of the BNC T connector.
4. Connect a 75 Ω BNC cable to the other end of the BNC T connector.
5. Connect the other end of the cable to the **CMPST 1** output on the SPG8000A.

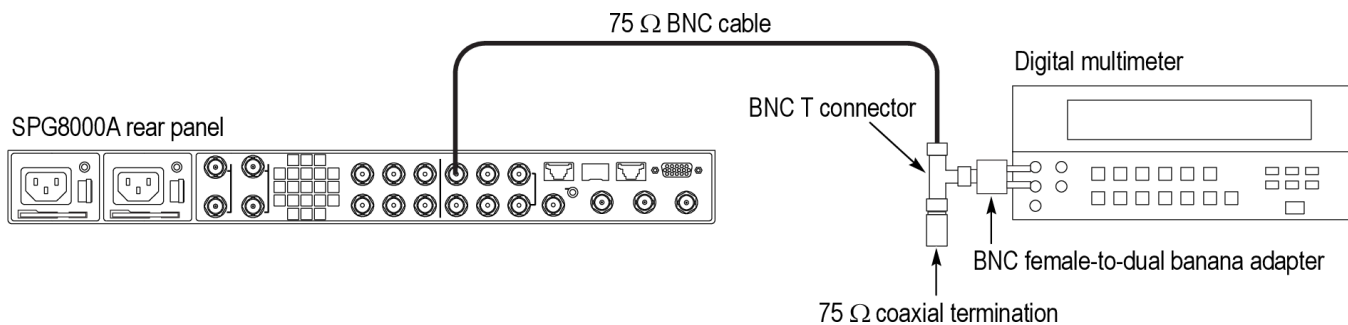

Figure 19: Setup for Composite offset and gain test

6. Set the CMPST 1 and CMPST 2 signals to NTSC as follows:
 - a. Press the **CMPST** button on the SPG8000A until you see **CMPST 1 : FORMAT** on the menu.
 - b. Use the left (◀) or right (▶) arrow button to select **NTSC**.
 - c. Press the **ENTER** button.
 - d. Repeat the previous substeps for the **CMPST 2** output.
7. Press the **CMPST** button until you see **CMPST 1** on the menu.
8. Use the up (▲) arrow button to select **CALIBRATION**.

9. Use the right (▶) arrow button to select **DAC Offset (0 V DC)**.
10. Press the **ENTER** button.
11. Record the voltmeter reading in the test record. This is the offset value.
12. Use the right (▶) arrow to select **DAC Gain (700 mV DC)**.
13. Press the **ENTER** button.
14. Record the value in the test record.
15. Calculate the difference between the 700 mV and 0 mV signal levels and record this in the test record.
16. Repeat steps 7 through 15 for CMPST 2.

Composite luminance - chrominance gain match test

This test verifies the luminance and chrominance gain match of the color bars signal. The following equipment is required for this test:

- Oscilloscope
 - 75 Ω BNC cable
 - 75 Ω feed-through terminator
1. Use the 75 Ω BNC cable to connect the **CMPST 1** connector on the SPG8000A to the **CH 1** of the oscilloscope, as shown.
 2. Connect the 75 Ω feed-through terminator to the loopthrough on the oscilloscope.

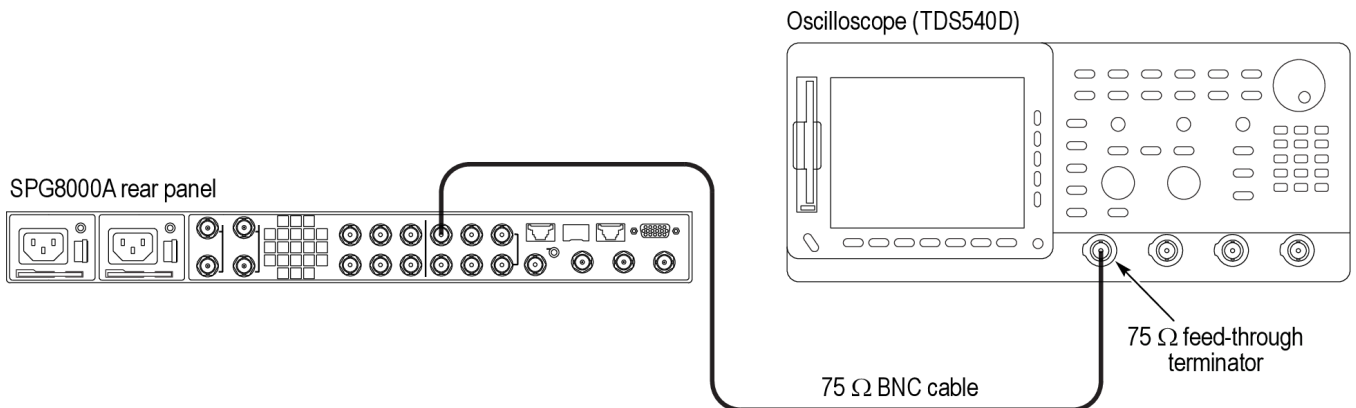

Figure 20: Setup for luminance and chrominance test

3. Select **PAL 75% Bars 100% white** signal for **CMPST 1** and **CMPST 2** as follows:
 - a. Press the **CMPST** button until you see **CMPST 1 : FORMAT** in the menu.
 - b. Press the right (▶) arrow button to select **PAL**, and then press the **ENTER** button.
 - c. Press the down (▼) arrow button to view the **CMPST 1 : TEST SIGNAL** menu.

- d. Press the right (▶) arrow button to select **75% Color Bar 100% White**, and then press **ENTER** button.
 - e. Press the **CMPST** button until you see **CMPST 2 : FORMAT** in the menu.
 - f. Press the right (▶) arrow button to select **PAL**, and then press the **ENTER** button.
 - g. Press the down (▼) arrow button to view the **CMPST 2 : TEST SIGNAL** menu.
 - h. Press the right (▶) arrow button to select **75% Color Bar 100% White**, and then press **ENTER** button.
4. To compare the tops of the white bar and the second (cyan) chroma packet to verify luma to chroma match, start by setting the oscilloscope settings as follows:

| Control | Setting |
|-----------------|-------------|
| Vertical | 10 mV/div |
| Vertical offset | 0.7 V |
| Trig position | 10% |
| Trig type | Edge rising |
| Trig level | 0.6 V |
| Record length | 50,000 |
| Time per div | 2.5 μ s |
| Trig hold-off | 50 μ s |

- 5. Turn on voltage cursors and measure the difference between the top of the white bar and the Cyan bar.
- 6. Record the difference in the test record for *Luma to Cyan bar match*.
- 7. Change the BNC cable connection from the **CMPST 1** connector on the SPG8000A to the **CMPST 2** connector on the SPG8000A and repeat steps 5 through 6.

Option GPS performance verification

The following procedures verify the functionality of the Option GPS Synchronization connectors.

NOTE. All of the procedures in this section only apply to SPG8000A units with Option GPS installed.

Required equipment The following table lists the required equipment for the following procedure.

Table 20: Required equipment for Option GPS performance verification

| Item | Qty. | Minimum requirements | Recommended equipment |
|---|--|--|---|
| GPS or GLONASS antenna feed with good signal level | 1 | Less than 5 dB attenuation since last amplifier | If a GPS or GLONASS antenna feed is not available, use the following equipment (or equivalent) to create a GPS signal source. <ul style="list-style-type: none"> ■ Trimble Bullet III: 5 V, 35 dB gain, antenna with F-connector ■ Cable: up to 200 ft Belden 1694A, with F connector on one end and a BNC on the other |
| NTSC Black sync source that is locked to GPS or GLONASS | 1 | NTSC signal with phase within 150 ns of the TAI epoch timing | GPS7 module in a TG8000 or equivalent ¹ |
| 6, 10, and 20 dB antenna pads | variable If antenna has no additional amps, one 6 dB and one 10 dB should be adequate. For a fully buffered system, 30 or 40 dB total is probably needed. | Use several pads that allow similar ranges | 6 dB, Mini-circuits HAT-6-75 10 dB, Mini-circuits HAT-10-75 20 dB, Mini-circuits HAT-20-75 |
| Waveform monitor | 1 | | Tektronix WFM8300 or WFM7120 with Option CPS |
| Voltmeter | 1 | | Fluke |
| LTC/GPIO breakout adapter cable | 1 | | Tektronix part number 012-1717-00 |
| 600 Ω LTC load with meter access | 1 | | Create this item by soldering a 600 Ω resistor to pins 2 and 3 of a female XLR |

¹ The type of GPS receiver in the reference system must match the type of GPS receiver in the DUT system.

Performance verification

| Item | Qty. | Minimum requirements | Recommended equipment |
|------------------------------------|------|--|--|
| Antenna splitter | 1 | Use to drive one signal into two GPS7 inputs | Any 2:1 splitter with appropriate connector adapters or GPS Source S12S with (3) SMA to BNC adapters, Tyco part number 1058083-1 or ZFDC-10-5-S with 3 SMA to BNC adapters, Tyco part number 1058083-1 |
| 75 Ω , precision terminator | 1 | | Tektronix part number 011-0102-03 |
| 75 Ω coaxial terminator | 2 | | Tektronix part number 011-0163-00 |
| BNC T | 2 | | Tektronix part number 103-0030-00 |
| BNC to Banana Plug adapter | 1 | | Pomona model 1269 |
| 75 Ω BNC cable | 4 | 3 ft long | Tektronix part number 012-0074-00 or MarkerTek 1894-B-B-3 |

Test record Photocopy this table and use it to record the performance test results.

Table 21: SPG8000A Option GPS test record

| Instrument Serial Number: Temperature: Date of Calibration: | | | Certificate Number: RH %: Technician: | | |
|---|--------------------------------------|--------------------------------------|---|-------|-------|
| Performance test | -Min | +Max | Measured | Value | Value |
| DC antenna output power voltage | | | | | |
| 0 V | | | | | |
| 3.3 V | 3.3 V | 4 V | | | |
| 5 V | 5 V | 6 V | | | |
| Antenna current and fault thresholds | | | | | |
| Flashing green (open circuit) | | | | Pass | Fail |
| Steady green (nominal load) | | | | Pass | Fail |
| Voltage with nominal load | 4.5 V | 5 V | | | |
| Steady red (short circuit) | | | | Pass | Fail |
| Lock to GPS or GLONASS signal from antenna | | | | | |
| Signal quality (reference unit) | 40 | 80 | | | |
| Difference in signal quality between reference unit and unit under test | ≤ 20 units from reference unit value | ≥ 20 units from reference unit value | | | |
| Frequency accuracy when locked to GPS or GLONASS | | | | | |
| Vector phase change | - 38 ° | + 38 ° | | | |
| Frame timing accuracy | | | | | |
| Timing | - 0.185 μs | + 0.185 μs | | | |
| Internal frequency | - 2.5 e ⁻⁶ | +2.5 e ⁻⁶ | | | |

Procedures Be sure to perform the Common Diagnostics Tests before proceeding. (See *Diagnostics tests* on page 32.)
 You can perform performance verification procedures individually, if needed.

Set to factory mode and load factory preset 1. Change the instrument to factory mode. (See *Set the SPG8000A to Factory Mode* on page 31.)

NOTE. *Although not all of the following tests need to be performed in factory mode, they can be. If you are going to perform all of the procedures, or a particular set of procedures, start up the instrument in factory mode at the start of the first procedure.*

Leave the instrument in factory mode until you are finished or the instructions say otherwise.

2. Load the factory default preset. (See *Load the factory preset* on page 32.)

DC antenna output power voltage test Perform the following procedure to check that the DC antenna power output is in the proper voltage range.

1. Connect the BNC-to-Banana-plug adapter to the voltmeter.
2. Connect the BNC T to the adapter.
3. Connect a 75 Ω BNC cable to the other end of the BNC T connector.
4. Connect the other end of the cable to the **GPS ANT** input on the rear of the SPG8000A.

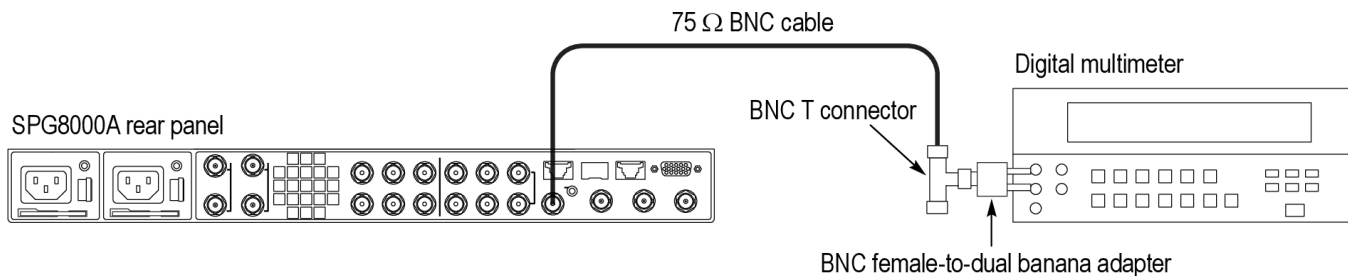

Figure 21: Setup for DC antenna output power voltage test

5. Measure the voltage and record the value in the test record.
6. Set the antenna voltage to 0 V as follows:
 - a. Press the **REF** button.
 - b. Use the up (\blacktriangle) or down (\blacktriangledown) arrow button to select **GPS ANTENNA POWER**.
 - c. Use the right (\blacktriangleright) arrow button to select **Off**.
 - d. Press the **ENTER** button.
7. Check that the voltmeter shows 0 V.

8. Record the result in the test record for the 0 V entry.
9. Set the antenna voltage to 3.3 V as follows:
 - a. Use the right (▶) arrow button to select **3.3 Volt**.
 - b. Press the **ENTER** button.
10. Check that the voltmeter shows between 3.3 V and 4 V.
11. Record the result in the test record for the 3.3 V entry.
12. Now set the antenna voltage to 5 V as follows:
 - a. Use the right (▶) arrow button to select **5 Volt**.
 - b. Press the **ENTER** button.
13. Check that the voltmeter shows between 5 V and 6 V.
14. Record the result in the test record for the 5 V entry.

Antenna current and fault thresholds test

Perform the following procedure to check that the antenna current and fault thresholds are within limits.

1. Use the equipment connection from the previous test. (See [Figure 21: Setup for DC antenna output power voltage test](#) on page 84.)
2. Set the antenna voltage to 5 V, if it is not already, as follows:
 - a. Press the **REF** button.
 - b. Use the up (▲) or down (▼) arrow button to select **GPS ANTENNA POWER**.
 - c. Use the right (▶) arrow button to select **5 Volt**.
 - d. Press the **ENTER** button.
3. Check that the antenna power LED on the rear panel of the SPG8000A is flashing green. This indicates an open circuit.
4. Record Pass or Fail in the test record.
5. Apply a 75 Ω precision terminator to the BNC T connector.
6. Check that the voltage is between 4.5 V and 5 V.
7. Record the result in the test record.
8. Check that the antenna power LED on the SPG8000A rear panel is a steady green. This indicates a nominal load.
9. Record the Pass or Fail in the test record.
10. Remove the BNC-to-Banana adapter from the BNC T, and install a second BNC T and a precision terminator on the end of the cable to the antenna input. This will exceed the allowed current on the antenna.

- 11.** Check that the antenna power LED on the SPG8000A rear panel is a steady red. This indicates a short circuit.
- 12.** Record the result in the test record.

Lock to GPS or GLONASS signal from antenna test

Perform the following procedure to check that the internal GPS system locks onto the minimum allowable signal. This test requires a reference GPS7 unit.



CAUTION. *The GPS receiver in the SPG8000A can receive both GPS and GLONASS signals. For this test, be sure to use a GPS7 module that can receive both GPS and GLONASS signals.*

In the following procedure, the type of GPS receiver in the reference system must match the type of GPS receiver in the DUT system. Earlier GPS7 modules can receive only GPS signals. Later Option GPS modules can receive both GPS and GLONASS signals.

1. Set the antenna power as needed by the antenna in the test system.
2. Connect an antenna splitter to the GPS or GLONASS input signal feed.
3. Connect one output of the splitter to the GPS or GLONASS antenna input of the reference unit and then power on the unit.
4. Connect the other output of the splitter to the **GPS ANT** input of the SPG8000A under test.

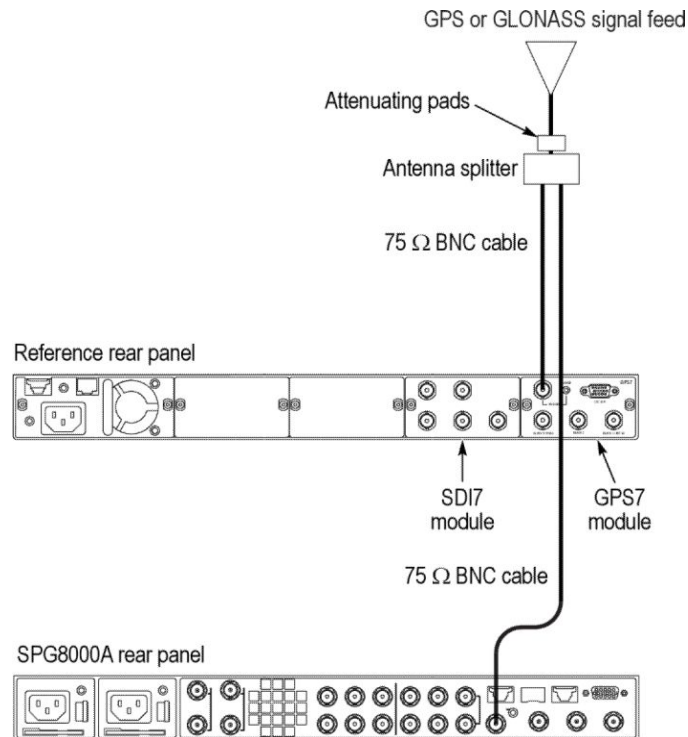

Figure 22: Setup for the GPS or GLONASS signal lock from antenna test

5. If necessary on the SPG8000A under test, set the GPS Constellation type to **GPS & GLONASS**:

NOTE. *You need to perform the following step only if your Option GPS module can receive both GPS and GLONASS signals.*

- a. Press the **REF** button to access the REFERENCE menu.
 - b. Use the up (▲) or down (▼) arrow button to select **GPS CONSTELLATION**.
 - c. Use the left (◀) or right (▶) arrow button to select **GPS & GLONASS**.
 - d. Press the **ENTER** button to make the selection.
6. If necessary on the reference system, set the GPS Constellation type to **GPS & GLONASS**:

NOTE. *You need to perform the following step only if your Option GPS module can receive both GPS and GLONASS signals.*

- a. Press the **MODULE** button to navigate to the **GPS7** module.
 - b. Use the up (▲) or down (▼) arrow button to select **GPS SETUP**.
 - c. Press the **ENTER** button.
 - d. Use the up (▲) or down (▼) arrow button to select **GPS CONSTELLATION**.
 - e. Use the left (◀) or right (▶) arrow button to select **GPS & GLONASS**.
 - f. Press the **ENTER** button to make the selection.
7. Check the signal quality on the reference unit as follows:
 - a. Use the up (▲) or down (▼) arrow button to select **STATUS** from the GPS7 module menu.
 - b. Use the left (◀) or right (▶) arrow button to select **Signal Quality**.
 - c. If the signal quality does not already show “Locked”, check that the signal quality changes from *No Signal* to *Low Signal* to *Acquiring satellites* to *Adjusting phase* to *Locked*.

NOTE. *It is okay if some steps are skipped. Depending on the signal level, it may take from a few seconds to several minutes to leave the “No Signal” state.*

8. Check the signal quality on the SPG8000A under test as follows:
 - a. Press the **STATUS** button.
 - b. Press the down (▼) arrow button until you see **STATUS : GPS**.

- c. Use the left (◀) or right (▶) arrow button to view the **GPS SIGNAL QUALITY: 30.0 Sats: 4/4** readout. Check that the signal quality value is greater than 30 and that the number of satellites is above 4/4.
9. Add attenuating pads between the antenna and the splitter until the signal quality on the reference unit is in the 40 to 80 range.
10. Record the signal quality of the reference unit in the test record.
11. Check that the signal quality on the SPG8000A under test is within 20 counts of the reference unit.
12. Record the difference between the reference unit and the SPG8000A under test in the test record.
13. Remove the attenuators from the input to the splitter and reconnect the signal from the antenna. If possible, leave the antenna on the SPG8000A under test connected during subsequent tests to allow the system to stabilize.

Frequency and frame timing accuracy test

This procedure checks that the frequency and frame timing are accurate when locked to GPS or GLONASS.

Frequency accuracy when locked to GPS or GLONASS.

1. Check that the antenna is connected to both a GPS7 reference module (or other reference instrument) and the **GPS ANT** connector of the SPG8000A under test.

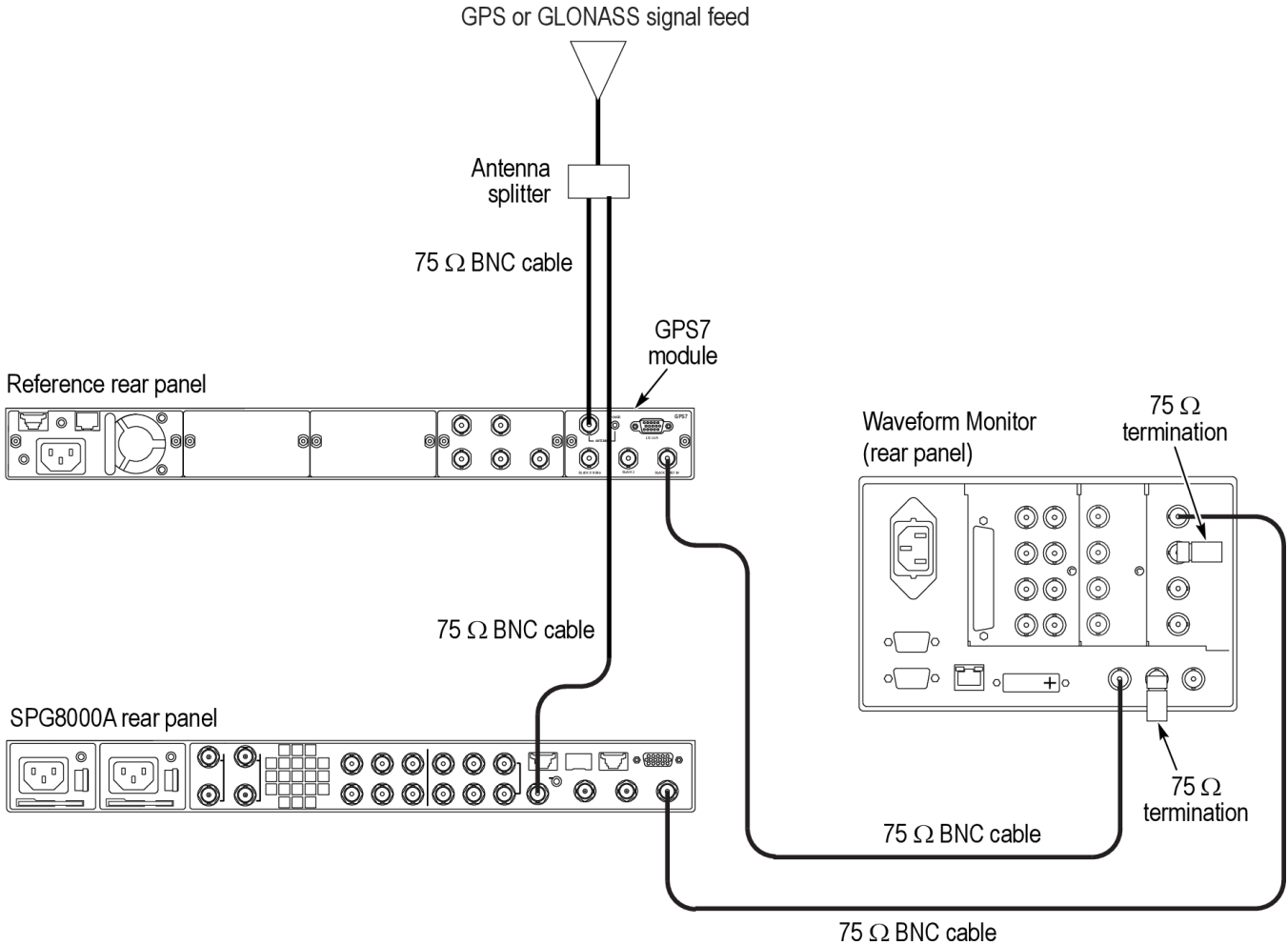

Figure 23: Setup for frequency accuracy and frame timing accuracy tests

2. Check that both the reference module and the SPG8000A under test have been on for 20 minutes to allow the ovens to warm up.
3. Check the signal quality on the reference module as follows:
 - a. Press the **MODULE** button until **GPS7** appears.
 - b. Use the up (▲) or down (▼) arrow button, if needed, to select **STATUS**.
 - c. Check that the top line of the status display shows **Locked**.
 - d. Use the left (◀) or right (▶) arrow button to select **Signal Quality**.
4. Check the value on the reference unit. A value of 30 or above is adequate.
5. Check the signal quality on the SPG8000A under test as follows:
 - a. Press the **STATUS** button.

- b. Press the down (▼) arrow button until you see **STATUS : GPS**.
 - c. Use the left (◀) or right (▶) arrow button to view the **GPS SIGNAL QUALITY: 30.0 Sats: 4/4** readout. Check that the signal quality value is greater than 30 and that the number of satellites is above 4/4.
6. Check the value on the SPG8000A under test. A value of 30 or above is adequate.
7. Go to the diagnostics page on the reference unit and check that the system is in **Fine** mode as follows. If it is not, then allow it to warm up and stabilize.
 - a. Use the up (▲) arrow button to select **DIAGNOSTICS**.
 - b. Press the **ENTER** button.
 - c. Press the right (▶) arrow to display **TUNE**.
 - d. Check that **Fine** shows on the right side of the display.
 - e. Press **BACK** to exit Diagnostics menu.
8. Go to the diagnostics page on the SPG8000A under test and check that the system is in **Fine** mode as follows. If it is not, then allow it to warm up and stabilize.
 - a. Press the **SYSTEM** button.
 - b. Use the up (▲) arrow button to select **DIAGNOSTICS**.
 - c. Press the **ENTER** button.
 - d. Check that you can see **SYSTEM : DIAGNOSTICS : TUNE** in the menu.
 - e. Press the right (▶) arrow to display the **Phase** and **DDS** values.
 - f. Check that **Fine** shows to the right of the readings. If it does not, allow more time for the system to stabilize.
 - g. Press **BACK** to exit the Diagnostics menu.
9. Set the **BLACK 1** output on the reference unit to NTSC as follows:
 - a. Use the up (▲) or down (▼) arrow button to select **SELECT OUTPUT**.
 - b. Use the left (◀) or right (▶) arrow button to select **Black 1**.
 - c. Press **ENTER** to display **INPUT-OUTPUT**.
 - d. Use the down (▼) arrow button to display **SELECT FORMAT**.
 - e. Press **ENTER** twice to select **NTSC** and **Black Burst**.
10. Set the **BLACK 1** output on the SPG8000A unit under test to NTSC as follows:
 - a. Press the **BLACK** button until you see **BLACK 1: FORMAT** on the menu.
 - b. If you see **NTSC** on the display, press the **ENTER** button. If you do not see **NTSC**, press the right (▶) arrow button until you do, and then press the **ENTER** button.

11. Connect **BLACK 1** of the reference unit to the reference input on the waveform monitor, and terminate the loop through with a 75 Ω terminator.
 12. Connect **BLACK 1** of the SPG8000A under test to the **CMPST A** input of the waveform monitor, and terminate the loop through with a 75 Ω terminator.
 13. Display the composite input on the waveform monitor and select external reference.
 14. View the Vector Display in full screen mode.
 15. Use the variable gain function to expand the burst to overlap the compass rose graticule.
 16. Write down the minimum and maximum vector phase you observe over a 30 second period.
 17. Calculate the difference and record the result in the test record.
 18. View the Timing Display in full screen mode.
 19. Record the timing value in the test record.
- Frame timing accuracy when locked to GPS or GLONASS.**
20. View the Timing Display in full screen mode.
 21. Record the timing value in the test record.

Internal frequency calibration test

Perform the following procedure to set the internal frequency of the base unit internal oscillator. This adjustment stores the current correction to the oven oscillator frequency while it is locked to a GPS, GLONASS or reference signal, to be used when in **Internal** mode. It can be done without any disruption to operation and is best done in the operating environment of the instrument.

1. Connect the power cord to the SPG8000A.
2. Check for error messages as the instrument starts.
3. Connect a GPS or GLONASS signal to the GPS ANT connector.

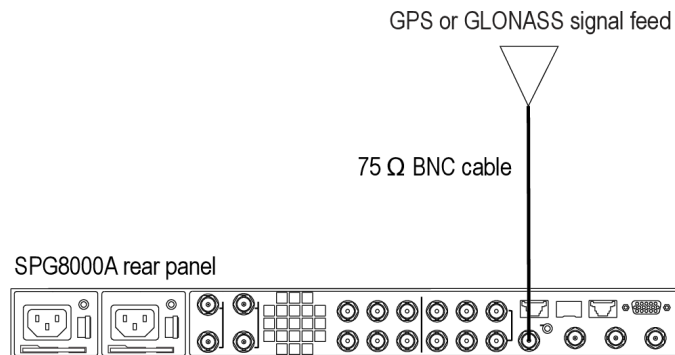

Figure 24: Setup for internal frequency calibration

4. Allow the instrument to warm up for at least 20 minutes.

5. Check that the signal on the SPG8000A under test is locked as follows:
 - a. Press the **STATUS** button.
 - b. Press the down (▼) arrow button until you see **STATUS : REFERENCE : GPS**.
 - c. Check that **Locked >>>>** shows on the display.
6. Go to the diagnostics page on the SPG8000A under test and check that the system is in **Fine** mode as follows. If it is not, then allow it to warm up and stabilize.
 - a. Press the **SYSTEM** button.
 - b. Use the up (▲) arrow button to select **DIAGNOSTICS**.
 - c. Press the **ENTER** button.
 - d. Check that you can see **SYSTEM : DIAGNOSTICS : TUNE** in the menu.
 - e. Press the right (▶) arrow to display the **Phase** and **DDS** values.
 - f. Check that **Fine** shows to the right of the readings. If it does not, allow more time for the system to stabilize.
7. Press the right (▶) arrow to display the **Tune** values.
8. Check the Tune values. This is the amount that the SPG8000A is tuning to lock to the GPS or GLONASS signal. If this is more than $\pm 0.1 \text{ e}^{-6}$, then oven calibration is recommended and you should proceed to step 8. Otherwise exit the procedure.
9. Calibrate the oven correction as follows:
 - a. Press the **SYSTEM** button.
 - b. Press the up (▲) arrow button several times until you see **CALIBRATE OVEN**.
 - c. Press the up (▲) arrow button until you see **DIAGNOSTICS**, and then press the **ENTER** button.
 - d. Press the down arrow button until you see **SYSTEM : DIAGNOSTICS : CALIBRATION** and a value such as **Cal: -0.13 e-6(2069204)**.
10. Record the value you see in the test record. This is the correction that is being applied to the internal oven in order to achieve calibration.

NOTE. *If the value is outside the test limits, then the Oven has drifted more than expected and might need to be replaced.*

Option PTP performance verification

The following procedures verify the functionality of the Option PTP synchronization connectors.

NOTE. All of the procedures in this section only apply to SPG8000A units with Option PTP installed.

Required equipment The following table lists the required equipment for the following procedure.

Table 22: Required equipment for Option PTP performance verification

| Item | Qty. | Minimum requirements | Recommended equipment |
|--------------------------------|------|--------------------------------|---|
| Reference signal generator | 1 | PTP reference input and output | Tektronix SPG8000A with Option PTP |
| Waveform monitor | 1 | Composite inputs | Tektronix WFM8300 with Option CPS |
| 75 Ω coaxial terminator | 2 | | Tektronix part number 011-0163-00 |
| 75 Ω BNC cable | 2 | 2 m long | Tektronix part number 012-0074-00 or MarkerTek 1894-B-B-3 |
| Cat 5 or 6 cable | 1 | 2 m long | |
| SPF modules | 2 | Compatible modules | Tektronix SPG8000A Option LX or SX |
| Optical fiber cable | 1 | 1 m long | |

Test record Photocopy this table and use it to record the performance test results.

Table 23: SPG8000A Option PTP test record

| Instrument Serial Number: Temperature: Date of Calibration: | | | Certificate Number: RH %: Technician: | | |
|---|------------|------------|---|-------|-------|
| Performance test | -Min | +Max | Measured | Value | Value |
| Master mode | | | | | |
| Master function | | | | Pass | Fail |
| RJ45 connector | | | | Pass | Fail |
| Timing offset | -1 μ s | +1 μ s | | Pass | Fail |
| Slave mode | | | | | |
| Slave function | | | | Pass | Fail |
| SFP connector | | | | Pass | Fail |
| Timing offset | -1 μ s | +1 μ s | | Pass | Fail |

Procedures Be sure to perform the *Common Diagnostics Tests* before proceeding. (See [Diagnostics tests](#) on page 32.)

You can perform performance verification procedures individually, if needed.

DUT references. The performance verification tests for Option PTP require a second SPG8000A with Option PTP. For convenience, the two instruments are named as follows in the procedures:

- DUT SPG8000A: The instrument being tested.
- Reference SPG8000A: The instrument being used as the reference.

PTP connector tests. There are two rear-panel connectors for PTP signals:

- RJ45 connector for an Ethernet cable
- SFP housing for an optical SPF module

In order to test both PTP ports, the procedures are written so that the RJ45 port is checked during the PTP Master mode test and the SFP port is checked during the PTP Slave mode test. If desired, either port can be used for either or both tests. However, if only one port is used, then the other port will not have been verified.

Master mode test Perform the following test to ensure that the PTP Master mode and PTP RJ45 connector are working correctly.

Configure the DUT SPG8000A.

1. Load the factory default settings. *Load the factory preset* on page 32
2. Set the PTP network settings as follows:
 - a. Press the **SYSTEM** button.
 - b. Press the down arrow button to select **SYSTEM : PTP NETWORK**, and then press **ENTER** to access the PTP Network menu.
 - c. If necessary, press the right arrow to select **Disable**. Press the **ENTER** button to confirm the selection and disable DHCP service.
 - d. Press the down arrow to select **SYSTEM : PTP: IP ADDRESS**, and then press **ENTER** to access the address edit mode.
 - e. Set the IP address to **192.168.1.3** by using the left/right arrow buttons to select a digit in the address and using the up/down arrow buttons to set the value for the selected address digit.
 - f. Press the **ENTER** button to confirm the address changes.
 - g. Press the down arrow to select **SYSTEM : PTP: SUBNET MASK**, and then press **ENTER** to access the address edit mode.
 - h. Set the subnet mask to **255.255.255.0** by using the left/right arrow buttons to select a digit in the address and using the up/down arrow buttons to set the value for the selected address digit.
 - i. Press the **ENTER** button to confirm the address changes.
 - j. Press the down arrow to select **SYSTEM : PTP: GATEWAY ADDRESS**, and then press **ENTER** to access the address edit mode.
 - k. Set the gateway address to **192.168.1.1** by using the left/right arrow buttons to select a digit in the address and using the up/down arrow buttons to set the value for the selected address digit.
 - l. Press the **ENTER** button to confirm the address changes.
 - m. Press the down arrow to select **SYSTEM : PTP: SWITCH**.
 - n. Press the right arrow button to select **Fully Crossed-Link**, and then press **ENTER** to confirm the selection.
3. Set the reference mode to internal:
 - a. Press the **REF** button to access the REFERENCE menu.
 - b. If necessary, press the right arrow button to select **Internal**.
 - c. Press **ENTER** to confirm the selection.
4. Enable the PTP Primary Master mode:
 - a. Press the **PTP** button to access the PTP menu.
 - b. If necessary, press the right arrow button to select **Enable Master**.
 - c. Press **ENTER** to confirm the selection.
5. Connect a cable between the Black 1 output and the CMPST A input of the waveform monitor.

6. Connect a 75 Ω termination to the second CMPST A input.

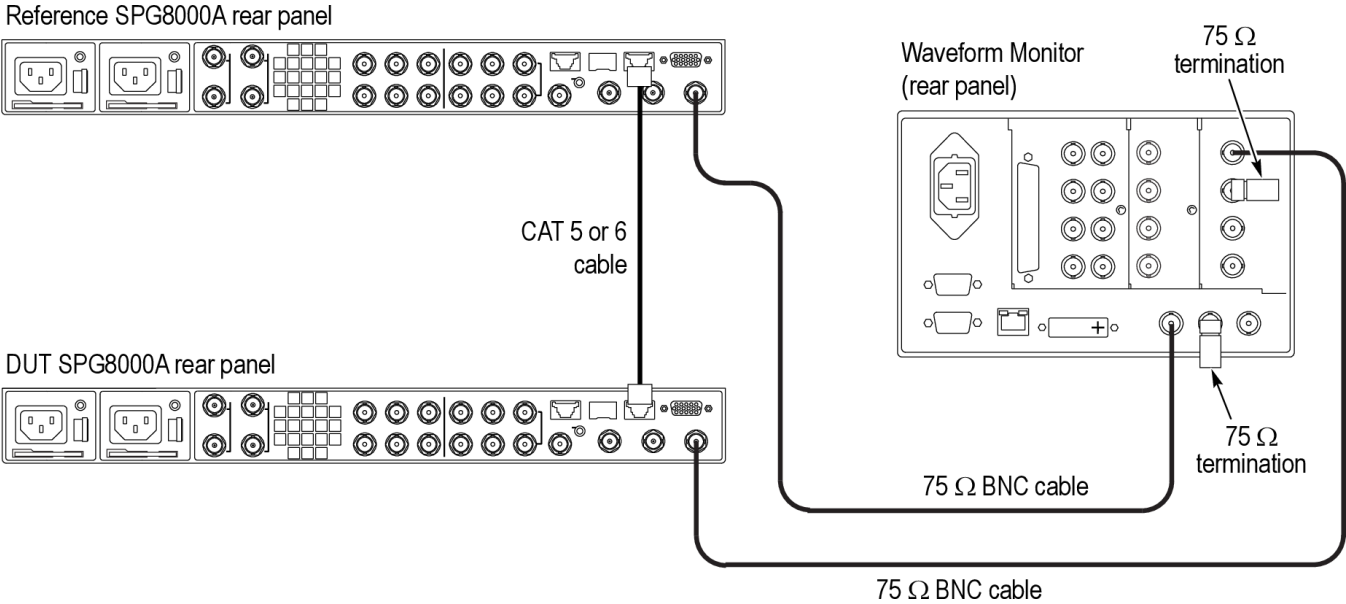

Figure 25: Setup for PTP Master mode tests

Configure the reference SPG8000A.

1. Load the factory default settings. *Load the factory preset* on page 32
2. Set the PTP network settings as follows:
 - a. Press the **SYSTEM** button.
 - b. Press the down arrow button to select **SYSTEM : PTP NETWORK**, and then press **ENTER** to access the PTP Network menu.
 - c. If necessary, press the right arrow to select **Disable**. Press the **ENTER** button to confirm the selection and disable DHCP service.
 - d. Press the down arrow to select **SYSTEM : PTP: IP ADDRESS**, and then press **ENTER** to access the address edit mode.
 - e. Set the IP address to **192.168.1.2** by using the left/right arrow buttons to select a digit in the address and using the up/down arrow buttons to set the value for the selected address digit.
 - f. Press the **ENTER** button to confirm the address changes.
 - g. Press the down arrow to select **SYSTEM : PTP: SUBNET MASK**, and then press **ENTER** to access the address edit mode.
 - h. Set the subnet mask to **255.255.255.0** by using the left/right arrow buttons to select a digit in the address and using the up/down arrow buttons to set the value for the selected address digit.
 - i. Press the **ENTER** button to confirm the address changes.
 - j. Press the down arrow to select **SYSTEM : PTP: GATEWAY ADDRESS**, and then press **ENTER** to access the address edit mode.
 - k. Set the gateway address to **192.168.1.1** by using the left/right arrow buttons to select a digit in the address and using the up/down arrow buttons to set the value for the selected address digit.
 - l. Press the **ENTER** button to confirm the address changes.
 - m. Press the down arrow to select **SYSTEM : PTP: SWITCH**.
 - n. Press the right arrow button to select **Fully Crossed-Link**, and then press **ENTER** to confirm the selection.
3. Set the reference mode to PTP:
 - a. Press the **REF** button to access the REFERENCE menu.
 - b. If necessary, press the right arrow button to select **PTP**.
 - c. Press **ENTER** to confirm the selection.
4. Connect a cable between the Black 1 output and the Reference input of the waveform monitor.
5. Connect a 75 Ω termination to the second Reference input.

Configure the waveform monitor.

1. Select to view the CMPST A input using the Timing Diagram display.
2. Set the monitor to use the external reference signal.

Test the DUT.

1. Press the **STATUS** button on the reference SPG8000A. If necessary, press the down (▼) arrow to see the lock status message. The message **Waiting for Master** should be displayed.
2. Connect the Cat 5 or 6 cable between the PTP RJ45 connectors on the DUT SPG8000A and the Reference SPG8000A.
3. You should see messages as the instrument progresses towards locking to the PTP signal. The message sequence is:
 - Waiting for Master
 - Setting PTP Frequency
 - Setting PTP Phase
 - Setting PTP Time
 - Adjusting SPG Phase
 - Locked

NOTE. *It should take approximately 3 minutes for the reference SPG8000A to lock to the PTP signal from the DUT SPG8000A.*

4. When the status message changes to **Locked**, record **Pass** in the test record for **Master function** and for **RJ45 connector**.
5. On the waveform monitor, check that the Timing Diagram display indicates a timing difference of less than $\pm 1 \mu\text{s}$. Record the measured offset in the test record for **Master mode Timing offset**, and then record **Pass** or **Fail** for the test result.

Slave mode tests Perform the following test to ensure that the PTP Slave mode and SFP connector are working correctly.

Configure the DUT SPG8000A.

1. If necessary, disconnect the Cat 5 or 6 cable that was installed between the PTP RJ45 ports on the DUT SPG8000A and reference SPG8000A in the previous Master mode test.
2. Load the factory default settings. *Load the factory preset* on page 32
3. Set the PTP network settings as follows:
 - a. Press the **SYSTEM** button.
 - b. Press the down arrow button to select **SYSTEM : PTP NETWORK**, and then press **ENTER** to access the PTP Network menu.
 - c. If necessary, press the right arrow to select **Disable**. Press the **ENTER** button to confirm the selection and disable DHCP service.
 - d. Press the down arrow to select **SYSTEM : PTP: IP ADDRESS**, and then press **ENTER** to access the address edit mode.
 - e. Set the IP address to **192.168.1.3** by using the left/right arrow buttons to select a digit in the address and using the up/down arrow buttons to set the value for the selected address digit.
 - f. Press the **ENTER** button to confirm the address changes.
 - g. Press the down arrow to select **SYSTEM : PTP: SUBNET MASK**, and then press **ENTER** to access the address edit mode.
 - h. Set the subnet mask to **255.255.255.0** by using the left/right arrow buttons to select a digit in the address and using the up/down arrow buttons to set the value for the selected address digit.
 - i. Press the **ENTER** button to confirm the address changes.
 - j. Press the down arrow to select **SYSTEM : PTP: GATEWAY ADDRESS**, and then press **ENTER** to access the address edit mode.
 - k. Set the gateway address to **192.168.1.1** by using the left/right arrow buttons to select a digit in the address and using the up/down arrow buttons to set the value for the selected address digit.
 - l. Press the **ENTER** button to confirm the address changes.
 - m. Press the down arrow to select **SYSTEM : PTP: SWITCH**.
 - n. Press the right arrow button to select **Fully Crossed-Link**, and then press **ENTER** to confirm the selection.
4. Set the reference mode to PTP:
 - a. Press the **REF** button to access the REFERENCE menu.
 - b. If necessary, press the right arrow button to select **PTP**.
 - c. Press **ENTER** to confirm the selection.
5. Connect a cable between the Black 1 output and the CMPST A input of the waveform monitor.

6. Connect a 75 Ω termination to the second CMPST A input.

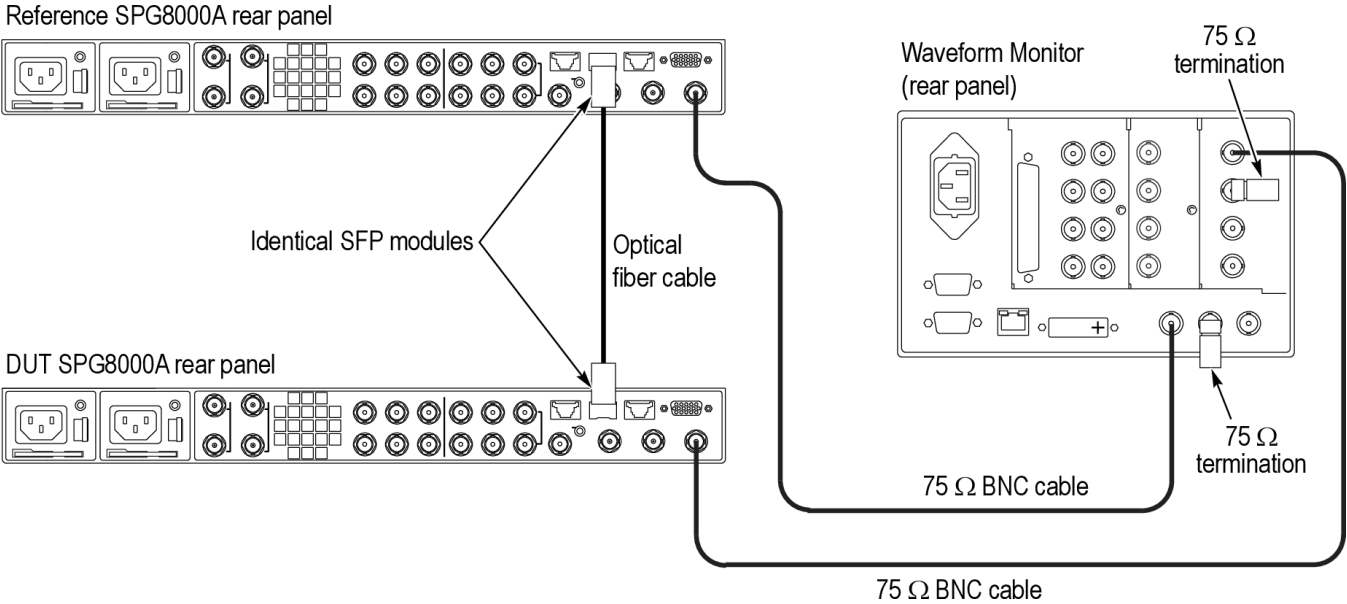

Figure 26: Setup for PTP Slave mode tests

Configure the reference SPG8000A.

1. Load the factory default settings. *Load the factory preset* on page 32
2. Set the PTP network settings as follows:
 - a. Press the **SYSTEM** button.
 - b. Press the down arrow button to select **SYSTEM : PTP NETWORK**, and then press **ENTER** to access the PTP Network menu.
 - c. If necessary, press the right arrow to select **Disable**. Press the **ENTER** button to confirm the selection and disable DHCP service.
 - d. Press the down arrow to select **SYSTEM : PTP: IP ADDRESS**, and then press **ENTER** to access the address edit mode.
 - e. Set the IP address to **192.168.1.2** by using the left/right arrow buttons to select a digit in the address and using the up/down arrow buttons to set the value for the selected address digit.
 - f. Press the **ENTER** button to confirm the address changes.
 - g. Press the down arrow to select **SYSTEM : PTP: SUBNET MASK**, and then press **ENTER** to access the address edit mode.
 - h. Set the subnet mask to **255.255.255.0** by using the left/right arrow buttons to select a digit in the address and using the up/down arrow buttons to set the value for the selected address digit.
 - i. Press the **ENTER** button to confirm the address changes.
 - j. Press the down arrow to select **SYSTEM : PTP: GATEWAY ADDRESS**, and then press **ENTER** to access the address edit mode.
 - k. Set the gateway address to **192.168.1.1** by using the left/right arrow buttons to select a digit in the address and using the up/down arrow buttons to set the value for the selected address digit.
 - l. Press the **ENTER** button to confirm the address changes.
 - m. Press the down arrow to select **SYSTEM : PTP: SWITCH**.
 - n. Press the right arrow button to select **Fully Crossed-Link**, and then press **ENTER** to confirm the selection.
3. Set the reference mode to internal:
 - a. Press the **REF** button to access the REFERENCE menu.
 - b. If necessary, press the right arrow button to select **Internal**.
 - c. Press **ENTER** to confirm the selection.
4. Enable the PTP Primary Master mode:
 - a. Press the **PTP** button to access the PTP menu.
 - b. If necessary, press the right arrow button to select **Enable Master**.
 - c. Press **ENTER** to confirm the selection.
5. Connect a cable between the Black 1 output and the Reference input of the waveform monitor.
6. Connect a 75 Ω termination to the second Reference input.

Configure the waveform monitor.

1. Select to view the CMPST A input using the Timing Diagram display.
2. Set the monitor to use the external reference signal.

Test the DUT.

1. Press the **STATUS** button on the DUT SPG8000A. If necessary, press the down (▼) arrow to see the lock status message. The message **Waiting for Master** should be displayed.
2. Install the compatible SFP modules on both the DUT SPG8000A and the reference SPG8000A.



CAUTION. *The SFP modules must be compatible for this test to function properly. Use either two SPG8000A Option LX modules or use two SPG8000A Option SX modules.*

3. Connect an optical fiber cable between the two SFP ports.
4. You should see messages as the instrument progresses towards locking to the PTP signal. The message sequence is:
 - Waiting for Master
 - Setting PTP Frequency
 - Setting PTP Phase
 - Setting PTP Time
 - Adjusting SPG Phase
 - Locked

NOTE. *It should take approximately 3 minutes for the DUT SPG8000A to lock to the PTP signal from the reference SPG8000A.*

5. When the status message changes to **Locked**, record **Pass** in the test record for **Slave function** and for **SFP connector**.
6. On the waveform monitor, check that the Timing Diagram display indicates a timing difference of less than $\pm 1 \mu\text{s}$. Record the measured offset in the test record for **Slave mode Timing offset**, and then record **Pass** or **Fail** for the test result.

Options SDI and 3G performance verification

The following procedures verify the functionality of the Option SDI connectors.

NOTE. All of the procedures in this section only apply to SPG8000A units with Option SDI installed. Some steps have setups that depend on whether Option 3G is also installed.

Required equipment The following table lists the required equipment for the following procedure.

Table 24: Required equipment for Option SDI performance verification

| Item | No. | Minimum requirement | Recommended equipment |
|--|-----|--|---|
| Waveform monitor | 1 | HD-SDI waveform monitor with 3 Gb/s capabilities | Tektronix WFM8300 with Option 3G and Option PHY |
| Digital signal analyzer | 1 | Digital signal analyzer with a 20 GHz electrical sampling module and a probe interface module | Tektronix DSA8200 with an 80E04 electrical sampling module and an 80A03 Tek Connect Probe Interface module with semirigid cable |
| Tekconnect 75 Ω to 50 Ω adapter with BNC input connector | 1 | | Tektronix part number TCA75 |
| Tekconnect adapter with BNC input connector | 1 | | Tektronix part number TCA-BNC |
| 1 m (3 ft) BNC to BNC high-bandwidth cable | 3 | Used to hook DUT to scope for Amplitude and rise time tests | Belden 1694, MarkerTek 1694-B-B-3 |
| Stable 10 kHz sine generator | 1 | CW sine wave, with 800 mV _{p-p} \pm 5% into 75 Ω , THD < 60 dBc, 10 kHz, and less than 50 mV DC offset | A Tek AFG3101 |
| Precision RMS voltmeter | 1 | | Keithley 2700 DMM |
| 6 dB SMA attenuator | 1 | | Tektronix part number 015-1001-01 |
| SMA (male) to BNC (female) adapter | 1 | | Tektronix part number 015-0554-00 |
| 75 Ω Precision terminator | 1 | | 75 Ω Precision terminator (Tektronix part number 011-0102-03) |
| BNC to Banana Plug adapter | 1 | | Pomona model 1269 |
| BNC T | 1 | | Tektronix part number 103-0030-00 |
| BNC (female) to BNC (female) 75 Ω barrel | 1 | | Amphenol part number 31-70019 |

Test record Photocopy this table and use it to record the performance test results.

Table 25: SPG8000A Option SDI test record

| Instrument Serial Number: Temperature: Date of Calibration: | | Certificate Number: RH %: Technician: | | | |
|---|-------------|---|---------|-------|-------|
| Performance test | | Minimum | Maximum | Value | Value |
| SDI diagnostics | PLL status | | | | |
| | Flex0 | | | Pass | Fail |
| | Flex1 | | | Pass | Fail |
| | DDS status | | | | |
| | DDS0 | | | Pass | Fail |
| | DDS1 | | | Pass | Fail |
| | Voltages | | | | |
| | +1.2 V | | | Pass | Fail |
| | +1.2 VA | | | Pass | Fail |
| | +3.3 V | | | Pass | Fail |
| | +3.3 VA | | | Pass | Fail |
| | +1.5 V | | | Pass | Fail |
| | +3.0 V | | | Pass | Fail |
| | +1.8 V | | | Pass | Fail |
| | Dref | | | Pass | Fail |
| | SRAM Memory | | | | |
| Addr Bus | | | Pass | Fail | |
| Data Bus | | | Pass | Fail | |
| Memory Test | | | Pass | Fail | |
| DDR2 Memory | | | | | |
| Addr Bus | | | Pass | Fail | |
| Data Bus | | | Pass | Fail | |
| Memory Test | | | Pass | Fail | |

Performance verification

| Instrument Serial Number: Temperature: Date of Calibration: | | Certificate Number: RH %: Technician: | | | |
|---|--|---|-----------|-------|-------|
| Performance test | | Minimum | Maximum | Value | Value |
| Output function and jitter (channel 1 and channel 2) | Signal 1A 1080 50p/ 1080 50i | | | Pass | Fail |
| | Jitter 1080 50p/ 1080 50i | 0 ns | 50 ps p-p | | |
| | Signal 1B 1080 59.94p/ 1080 59.94i | | | Pass | Fail |
| | Jitter 1080 59.94p/ 1080 59.94i | 0 ns | 50 ps p-p | | |
| | Signal 1B 1080 24p | | | Pass | Fail |
| | Jitter 1080 24p | 0 ns | 50 ps p-p | | |
| | Signal 2A 1080 50p/ 1080 50i | | | Pass | Fail |
| | Jitter 1080 50p/ 1080 50i | 0 ns | 50 ps p-p | | |
| | Signal 2B 1080 59.94p/ 1080 59.94i | | | Pass | Fail |
| | Jitter 1080 59.94p/ 1080 59.94i | 0 ns | 50 ps p-p | | |
| | Signal 2B 1080 24p | | | Pass | Fail |
| | Jitter 1080 24p | 0 ns | 50 ps p-p | | |
| Amplitude characterization | DMM measurement (Typically, 0.2880 V) | | | | |
| | Cycle RMS (Typically, 116 mV) | | | | |
| | Cycle mean (Typically, 1 mV) | | | | |
| | RMS amplitude of sine wave (Typically, 116 mV) | $\text{SQRT}((\text{cycle RMS})^2 - (\text{cycle mean})^2)$ | | | |
| | Attenuation factor | 2.35 | 2.55 | | |

| Instrument Serial Number: Temperature: Date of Calibration: | | Certificate Number: RH %: Technician: | | | |
|---|-----------------------------------|---|---------|-------|-------|
| Performance test | | Minimum | Maximum | Value | Value |
| SDI Output Amplitude (channel 1 and channel 2) | Signal 1A amplitude calculated | 776 mV | 824 mV | | |
| | Signal 1B amplitude calculated | 776 mV | 824 mV | | |
| | Signal 2A amplitude calculated | 776 mV | 824 mV | | |
| | Signal 2B amplitude calculated | 776 mV | 824 mV | | |
| SDI Rise and Fall Time (HD and 3G) Signal 1A | Rise time | 0 ps | 135 ps | | |
| | Fall time | 0 ps | 135 ps | | |
| | Difference | -50 ps | +50 ps | | |
| SDI Rise and Fall Time (SD) Signal 1A | Rise time | 400 ps | 1000 ps | | |
| | Fall time | 400 ps | 1000 ps | | |
| | Difference | -500 ps | +500 ps | | |
| SDI Rise and Fall Time (HD and 3G) Signal 1B | Rise time | 0 ps | 135 ps | | |
| | Fall time | 0 ps | 135 ps | | |
| | Difference | -50 ps | +50 ps | | |
| SDI Rise and Fall Time (SD) Signal 1B | Rise time | 400 ps | 1000 ps | | |
| | Fall time | 400 ps | 1000 ps | | |
| | Difference | -500 ps | +500 ps | | |
| SDI Rise and Fall Time (HD and 3G) Signal 2A | Rise time | 0 ps | 135 ps | | |
| | Fall time | 0 ps | 135 ps | | |
| | Difference | -50 ps | +50 ps | | |
| SDI Rise and Fall Time (SD) Signal 2A | Rise time | 400 ps | 1000 ps | | |
| | Fall time | 400 ps | 1000 ps | | |
| | Difference | -500 ps | +500 ps | | |
| SDI Rise and Fall Time (HD and 3G) Signal 2B | Rise time | 0 ps | 135 ps | | |
| | Fall time | 0 ps | 135 ps | | |
| | Difference | -50 ps | +50 ps | | |
| SDI Rise and Fall Time (SD) Signal 2B | Rise time | 400 ps | 1000 ps | | |
| | Fall time | 400 ps | 1000 ps | | |
| | Difference | -500 ps | +500 ps | | |

- Preparation** Be sure you have performed the performance verification preparation before proceeding. (See [Preparation](#) on page 31.)
- Performance verification procedures can be performed individually, if needed.

Check for Option 3G Check whether Option 3G is installed on your instrument. If Option 3G is installed, then you should use the setups in the following procedures that are called out for Option 3G.

1. Press the **SYSTEM** button to access the SYSTEM menu.
2. Press the up (▲) or down (▼) arrow button to select **SYSTEM : OPTIONS**. The second line of the display lists the installed options. The readout will show **3G** if Option 3G is installed.

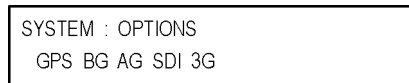

3080-061

SDI diagnostics Check the SDI diagnostics before performing the performance verification tests. Some of the SDI diagnostics are available only when the instrument is in factory mode.

1. Change the instrument to factory mode. (See [Set the SPG8000A to Factory Mode](#) on page 31.)
2. Load the factory default preset. (See [Load the factory preset](#) on page 32.)
1. Press the **SYSTEM** button to access the SYSTEM menu.
2. Use the up (▲) or down (▼) arrow button to select **SYSTEM : DIAGNOSTICS**, and then press the **ENTER** button.
3. Use the down (▼) arrow button to view the **PLL STATUS MAIN** display.
4. Use the right (▶) arrow button to view the **PLL STATUS SDI** display.
5. Check that **Flex0** and **Flex1** both show **Lock**, and then record Pass or Fail in the test record.
6. Use the right (▶) arrow button to view the **DDS STATUS SDI** display.
7. Check that **DDS0 Phase** and **DDS1 Phase** both show **Lock**, and then record Pass or Fail in the test record.
8. Use the down (▼) arrow button to view the **VOLTAGE** display.
9. Use the left (◀) arrow button to view the **VOLTAGE SDI BRD** displays 1 through 4.
10. Check that all voltages show **OK** for each VOLTAGE SDI BRD display, and then record Pass or Fail in the test record.
11. Use the down (▼) arrow button to select **SRAM ADDR BUS 1**.

12. Use the right (▶) arrow button to view the **SRAM ADDR BUS** displays 1 through 3.
13. Check that all buses show **(OK)** for each SRAM ADDR BUS display, and then record Pass or Fail in the test record.
14. Use the down (▼) arrow button to select **SRAM DATA BUS 1**.
15. Use the right (▶) arrow button to view the **SRAM DATA BUS** displays 1 through 3.
16. Check that all buses show **(OK)** for each SRAM DATA BUS display, and then record Pass or Fail in the test record.
17. Use the down (▼) arrow button to select **SRAM MEM TEST**, and then press the **ENTER** button to start the test. The SRAM memory test takes approximately 60 seconds to complete.
18. Check that the display reads **SRAM: 0 bad sectors detected**, and then record Pass or Fail in the test record.
19. Use the down (▼) arrow button to select **DDR2 ADDR BUS 1**.
20. Use the right (▶) arrow button to view the **DDR2 ADDR BUS** displays 1 and 2.
21. Check that all buses show **(OK)** for each DDR2 ADDR BUS display, and then record Pass or Fail in the test record.
22. Use the down (▼) arrow button to select **DDR2 DATA BUS 1**.
23. Use the right (▶) arrow button to view the **DDR2 DATA BUS** displays 1 and 2.
24. Check that all buses show **(OK)** for each DDR2 DATA BUS display, and then record Pass or Fail in the test record.
25. Use the down (▼) arrow button to select **DDR2 MEM TEST**, and then press the **ENTER** button to start the test. The DDR2 memory test takes approximately 7 seconds to complete.
26. Check that the display reads **DDR2: 0 errors detected**, and then record Pass or Fail in the test record.
27. Press the **BACK** button to exit the **DIAGNOSTICS** submenu.

Exit factory mode. Exit the factory mode to recover from the memory tests before continuing with the next verification steps:

1. Remove and then reattach the power cord to restart the SPG8000A.

Output functional and jitter test

1. Connect a 1 m cable from the **SDI 1A** output on the SPG8000A under test to the SDI A input of a WFM8300 with Options 3G and PHY.

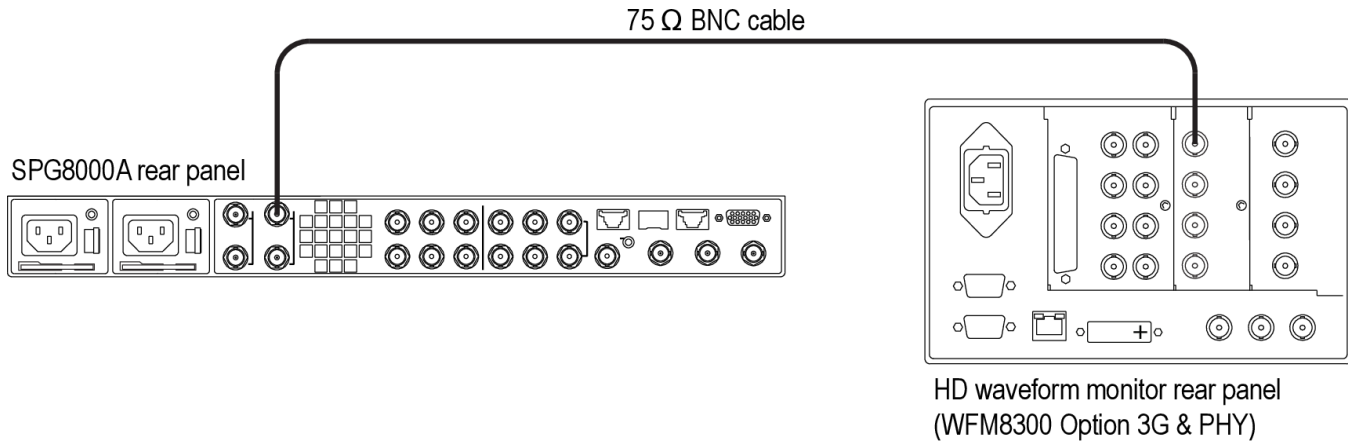

Figure 27: Setup for output and jitter test

2. Press the **SDI** button on the SPG8000A. You should see **SDI 1: OUTPUT MODE** in the menu.
3. Press the left (◀) or right (▶) arrow button to select the appropriate output mode as listed below. When the desired output mode is displayed, press the **ENTER** button to confirm the selection.
 - Option 3G installed: select **3G-Level A (1920 × 1080)**
 - Option 3G not installed: select **HD (1920 × 1080)**
4. Press the down (▼) arrow button until you see **FORMAT** in the menu.
5. Press the left (◀) or right (▶) arrow button to select the appropriate output mode as listed below. When the desired output mode is displayed, press the **ENTER** button to confirm the selection.
 - Option 3G installed: select **1080 50p**
 - Option 3G not installed: select **1080 50i**
6. Check that the WFM8300 displays the selected format in the status bar:
 - Option 3G installed: **1080 50p** is displayed
 - Option 3G not installed: **1080 50i** is displayed
7. Record Pass or Fail in the test record.
8. Select a tile on the WFM8300 and press the **FULL** button to view the display full screen.
9. Press the **EYE** button on the WFM8300. If necessary, press and hold the **EYE** button to access the menu and set the jitter HP filter to 100 kHz.

10. Set the test signal on the SPG8000A to 75% Color Bars (75% White) as follows:
 - a. Press the down (▼) arrow button until you see **TEST SIGNAL** in the menu, and then press the **ENTER** button.
 - b. Press the right (▶) arrow button until you see **75% Color Bars (75% White)**.
 - c. Press the **ENTER** button.
11. Measure the jitter on the WFM8300 as follows:
 - a. Set the WFM8300 vertical gain to 5x.
 - b. Set the WFM8300 horizontal magnification to 10x.
 - c. Center an eye crossing on the WFM8300 screen.
 - d. Press the WFM8300 Display button, and then turn on Infinite Persistence and set the waveform intensity to 50%.
 - e. Turn on the WFM8300 time cursors.
 - f. Shift the WFM8300 trace position to restart the persistence. Wait 30 seconds, and then use the time cursors to measure the width of the eye at the narrowest point on the WFM8300 display.
12. Record the jitter reading in the test record.
13. Move the cable from the SDI 1A connector to the **SDI 1B** connector.
14. Repeat steps 4 through 12 for the **SDI 1B** output using the following format:
 - Option 3G installed: select **1080 59.94p**
 - Option 3G not installed: select **1080 59.94i**
15. Repeat steps 2 through 12 for the **SDI 1B** output, but change the Output Mode to **HD (1920 x 1080)** and the format to **1080 24p**.
16. Move the cable from the SDI 1B connector to the **SDI 2A** connector.
17. Press the **SDI** button on the SPG8000A until you see **SDI 2: OUTPUT MODE**.
18. Repeat steps 2 - 12 for the **SDI 2A** output.
19. Move the cable from the SDI 2A connector to the **SDI 2B** connector.
20. Repeat steps 14 - 15 for the **SDI 2B** output.

Amplitude characterization

There are two parts to this test: Part A and Part B. Part A sets up a reference to the DMM. Part B characterizes the test system.

Part A: Reference against the DMM.

1. Connect the equipment as follows:
 - a. One end of a 1 m high bandwidth cable to the AFG3101 output.
 - b. The other end of the 1 m cable to the BNC T.
 - c. The BNC T to a BNC to banana adapter.
 - d. The other end of the BNC T to a precision terminator.
 - e. The end of the banana adapter to the input of the DMM.

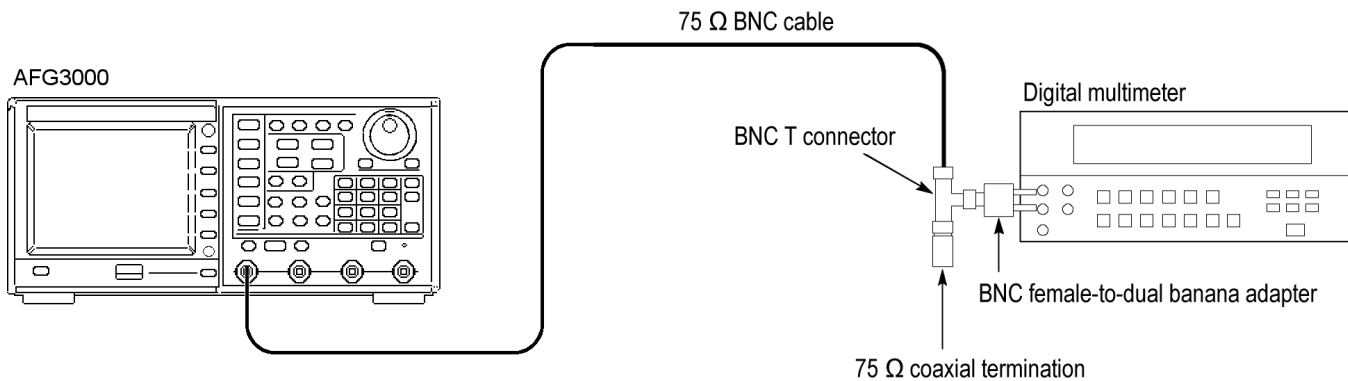

Figure 28: Setup for reference against the DMM

2. Set the AFG3101 to output a sine wave into a load impedance of 75 Ω.
3. Set the AFG3101 to a 10 kHz output into a load impedance of 75 Ω.
4. Set the AFG3101 to an 800 mV_{p-p} output into a load impedance of 75 Ω.
5. Check that the output of the AFG3101 is On.
6. Set the DMM to measure AC voltage using a medium filter setting. Set the range to allow for four digits of RMS amplitude.
7. Record the DMM measurement in the test record.

Set up the digital signal analyzer



CAUTION. *Electrostatic discharge can damage the oscilloscope modules. To prevent damage, always work in a static free environment and discharge the static voltage from your body by wearing a grounded antistatic wrist strap while handling these modules.*

1. Install the 80A03 output cable into the Channel 1/2 slot of the oscilloscope.
2. Install the 80E04 sampling head into the 80A03 adapter and connect the two using the SMA cables.
3. Install the TCA-75 into the left port of the 80A03.

4. Install the TCA-BNC into the right port of the 80A03.

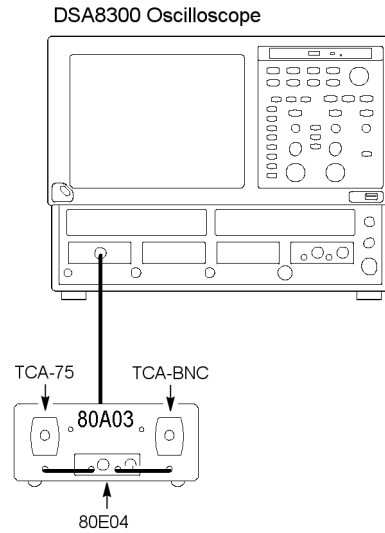

Figure 29: Set up the digital signal analyzer

5. If needed, press the Default Settings button on the oscilloscope.
6. Press the Channel 1 button on the 80E04 sampling head to activate Channel 1.

Part B: characterization of the test system

1. Connect the equipment as follows:
 - a. AFG3101 output to 1 m high bandwidth cable.
 - b. The other end of the cable to a TCA-75.
 - c. The TCA-75 to the 80A03 in the oscilloscope and plug-in.
 - d. A 50 Ω cable from the AFG3101 trigger output.
 - e. The other end of the 50 Ω cable to the BNC to SMA adapter.
 - f. The SMA adapter to the 6 dB pad.
 - g. The 6 dB pad to the trigger direct input on the oscilloscope.

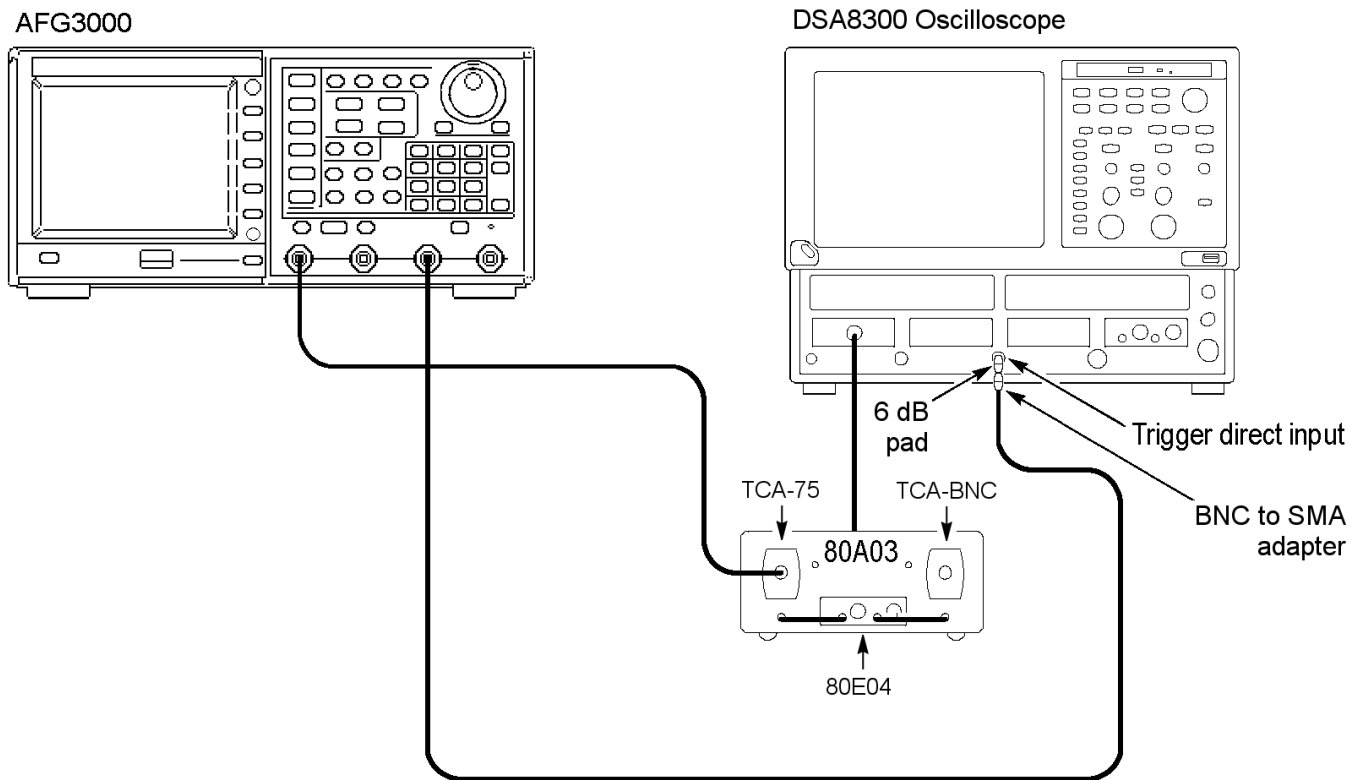

Figure 30: Setup for characterization of the test system

2. Keep the AFG3101 at the same output as in Part A of this test.
3. Set the oscilloscope to a horizontal scale of 20 μs.
4. Set the oscilloscope to a vertical scale of 50 mV.
5. Set the oscilloscope to averaging 16 and set the record length to 4000 points.
6. On the oscilloscope, select measurement 1 and then pulse amplitude and select it to measure Cycle RMS.
7. On the oscilloscope, select measurement 2 and then pulse amplitude and select it to measure Cycle Mean.
8. Record the Cycle RMS and Cycle Mean values in the test record.
9. Calculate the corrected RMS amplitude of the sine wave:

$$\text{SQRT}((\text{cycle RMS})^2 - (\text{cycle mean})^2)$$

10. Record the result in the test record.
11. Calculate the total attenuation factor for the system. This is the DMM measurement divided by the corrected RMS sine wave amplitude. This attenuation factor will be used after measuring the signal outputs in the next test.
12. Record the attenuation factor value in the test record.
13. Enter the attenuation factor value into the oscilloscope:
 - a. On the oscilloscope, press the SETUP DIALOG button.
 - b. Select the “Vert” tab from the top of the setup page.
 - c. Select the “External Attenuation” box, and then enter the attenuation factor calculated in step 11 above.

SDI output amplitude

Perform this test with the instrument in factory mode. (See [Set the SPG8000A to Factory Mode](#) on page 31.)

Perform this test after you have performed the *Amplitude characterization procedure*. (See [Amplitude characterization](#) on page 111.)



CAUTION. The serial output level can be adjusted when the instrument is in factory mode. Be careful not to accidentally adjust this level, as this will invalidate the factory calibration. If you need to perform a serial output level adjustment, see the SPG8000A service manual for the procedure.

1. Connect a 75 Ω cable from the **SDI 1B** output on the SPG8000A through the BNC to SMA adapter (with or without the 6 dB pad) to the trigger direct input on a sampling oscilloscope.
2. Connect a 1 m high-bandwidth cable from the **SDI 1A** output of the SPG8000A to the TCA75 BNC on the oscilloscope adapter.

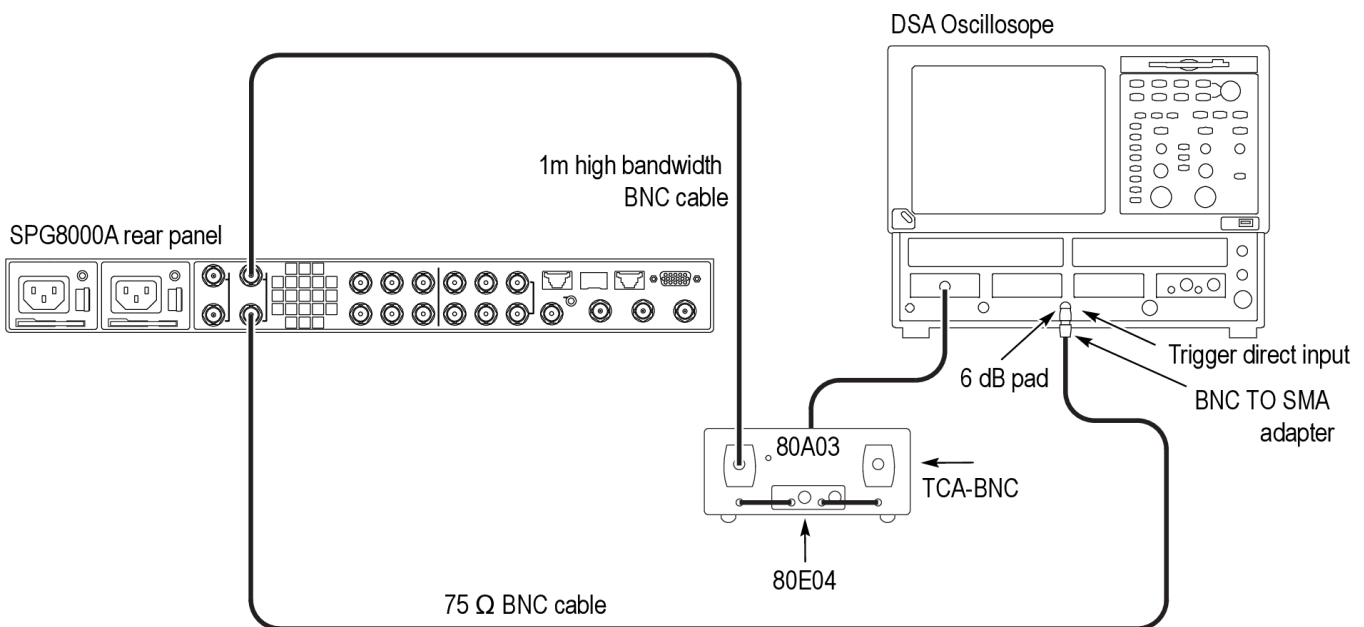

Figure 31: Setup for SDI output amplitude test

3. Set the SDI calibration signal for **SDI 1A** to 20 bits square on the SPG8000A as follows:
 - a. Press the **SDI** button on the SPG8000A.
 - b. Use the up (**▲**) arrow button to select **CALIBRATION**. You should see **Channel 1 : Top** in the menu.
 - c. Press the **ENTER** button.
 - d. Press the right (**►**) arrow button to select **20 bits Square**.
4. Set the scope to averaging 16 and set the record length to 4000 points, the time/div to 2 ns, and the amplitude per division to 100 mV.
5. On the scope, select Measurement 3, Pulse-Amplitude, and then Amplitude to measure the amplitude on the flat part of the long pulse.
6. Right click on the measurement readout, and select **Show Statistics** and **Show Annotations** from the pop-up menu.

7. Press the **Clear Data** button on the oscilloscope and wait about 5 seconds before proceeding to the next step.
8. Record the average value, which is indicated by the letter μ . Multiply μ by the attenuation factor you obtained in step 11 of the previous test.

NOTE. *If you entered the attenuation factor into the scope at the end of the amplitude characterization test (See [Amplitude characterization](#) on page 111), then the scope will display the multiplication result.*

9. Record the result in the test record.
10. Swap the signal cables between the SDI 1A and SDI 1B connectors so that **SDI 1A** connects to the trigger input and **SDI 1B** connects to the adapter.
11. Repeat steps 7 through 9 for the SDI 1B output.
12. Move the signal cable from the **SDI 1A** connector to the **SDI 2B** connector, and move the signal cable from the **SDI 1B** to the **SDI 2A** connector.
13. Repeat steps 7 through 12 for the SDI 2A and SDI 2B outputs.
14. Press the **BACK** button to exit the SDI calibration mode.
15. If you are performing the verification procedures in order, you can skip forward to step 1 of the *SDI rise and fall time* test. Otherwise, proceed to the next step.
16. Exit factory mode by removing and then reattaching the power cord to restart the SPG8000A.

SDI rise and fall time

Perform this test with the instrument in factory mode. (See [Set the SPG8000A to Factory Mode](#) on page 31.)

This procedure uses the same equipment setup as the previous procedure. (See [Figure 31: Setup for SDI output amplitude test](#) on page 116.)



CAUTION. *The serial output level can be adjusted when the instrument is in factory mode. Be careful not to accidentally adjust this level, as this will invalidate the factory calibration. If you need to perform a serial output level adjustment, see the SPG8000A service manual for the procedure.*

1. Connect a 75 Ω cable from the **SDI 1B** connector in the SPG8000A through the SMA to BNC adapter (with or without the 6 dB pad) to the trigger direct input on a sampling oscilloscope.
2. Connect a cable from the **SDI 1A** output of SPG8000A to the TCA75 BNC on the oscilloscope adapter.

3. Set the SDI calibration signal for SDI 1A to 20 bits square on the SPG8000A as follows:
 - a. Press the **SDI** button on the SPG8000A.
 - b. Use the up (**▲**) arrow button to select **SDI 1 : CALIBRATION**. You should see **Channel 1 : Top** in the menu.
 - c. Press the **ENTER** button.
 - d. Press the right (**▶**) arrow button to select **20 bits Square**.
4. On the oscilloscope, set the horizontal scale to 200 ps.
5. Set the oscilloscope to averaging 16 and set the record length to 4000 points.
6. On the oscilloscope, select Measurement 4 and then Pulse-Timing for the Rise Time.
7. Select the Reference Level tab from Measure and set the reference high to 80% and the low to 20%.
8. Select Measurement 5 and then Pulse-Timing for the Fall Time.
9. Select the Reference Level tab from Measure and set the reference high to 80% and the low to 20%.
10. Set the horizontal position to put the rising edge of the waveform about 2.5 divisions to the left of center.
11. Measure the rise time and record the result in the test record.
12. Use the horizontal position knob to put the falling edge about 2.5 divisions left of center.
13. Measure the fall time and record the result in the test record.
14. Check that the difference between the rise and fall times is within the specified limits and record the result in the test record.
15. Swap the signal cables between the SDI 1A and SDI 1B connectors so that **SDI 1A** connects to the trigger input and **SDI 1B** connects to the adapter.
16. Repeat steps 10 through 14 for the SDI 1B output.
17. Move the signal cable from the **SDI 1A** connector to the **SDI 2B** connector, and move the signal cable from the **SDI 1B** connector to the **SDI 2A** connector.
18. Repeat steps 10 through 16 for the SDI 2A and SDI 2B outputs.
19. Press the **BACK** button to exit the SDI calibration mode.
20. Disconnect all signal cables from the SPG8000A.
21. Set the SDI output mode to SD:
 - a. Press the **SDI** button. **SDI 1 : OUTPUT MODE** should be displayed.
 - b. Use the left (**◀**) or right (**▶**) arrow button to select the **SD** output mode. Press the **ENTER** button to confirm the selection.

- c. Press the down (▼) arrow button to select **SDI 1 : FORMAT**.
 - d. Use the left (◀) or right (▶) arrow button to select the **525 59.94i** format. Press the **ENTER** button to confirm the selection.
22. Connect a 1 m cable from the SDI 1A output to the 3G SDI A input of a WFM8300 with Options 3G and PHY. (See [Figure 27: Setup for output and jitter test](#) on page 110.)
 23. Set up the WFM8300 to display an eye diagram and eye measurements full screen.
 24. Record the rise time, fall time, and difference in the test record.
 25. Move the cable from the SDI 1A connector to the SDI 1B connector.
 26. Repeat step 24 for the SDI 1B connector.
 27. Repeat steps 21 - 26 for the SDI 2A and SDI 2B connectors.

Exit factory mode. Exit the factory mode.

1. Remove and then reattach the power cord to restart the SPG8000A.

